



technical solutions

instructions
profiles
accessories



DPS manuals

TABLE OF CONTENTS

INSTRUCTIONS

assembly instructions	4
types of stretch membranes	9

SYSTEM PROFILES

STANDARD COLLECTION	11
SLIM COLLECTION	35
Wall2Wall COLLECTION	57
TRENDERO COLLECTION	75

CEILING ACCESSORIES

profile connectors	78
inspection hatches	82
ceiling membrane perforation reinforcement	83

ASSEMBLY INSTRUCTIONS

The ceiling membrane should be stretched gradually and evenly during installation.

EXAMPLES OF PROPER SEQUENCE IN ATTACHING THE HARPOON TO THE PROFILE:

FIG. 1 | RECTANGULAR CEILING

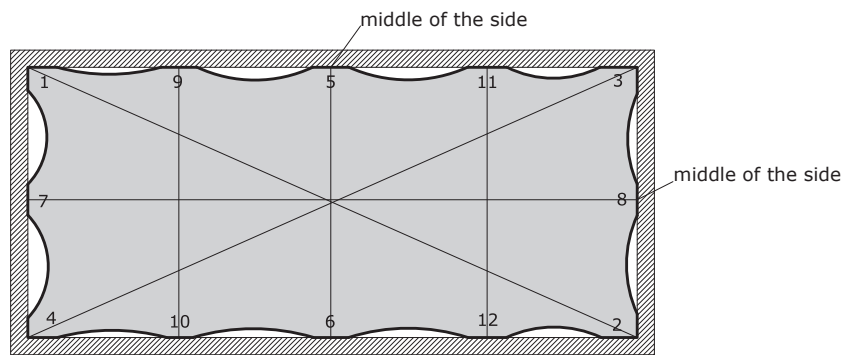

FIG. 2 | ROUND CEILING

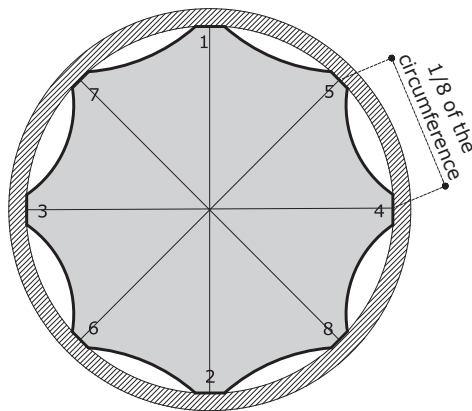
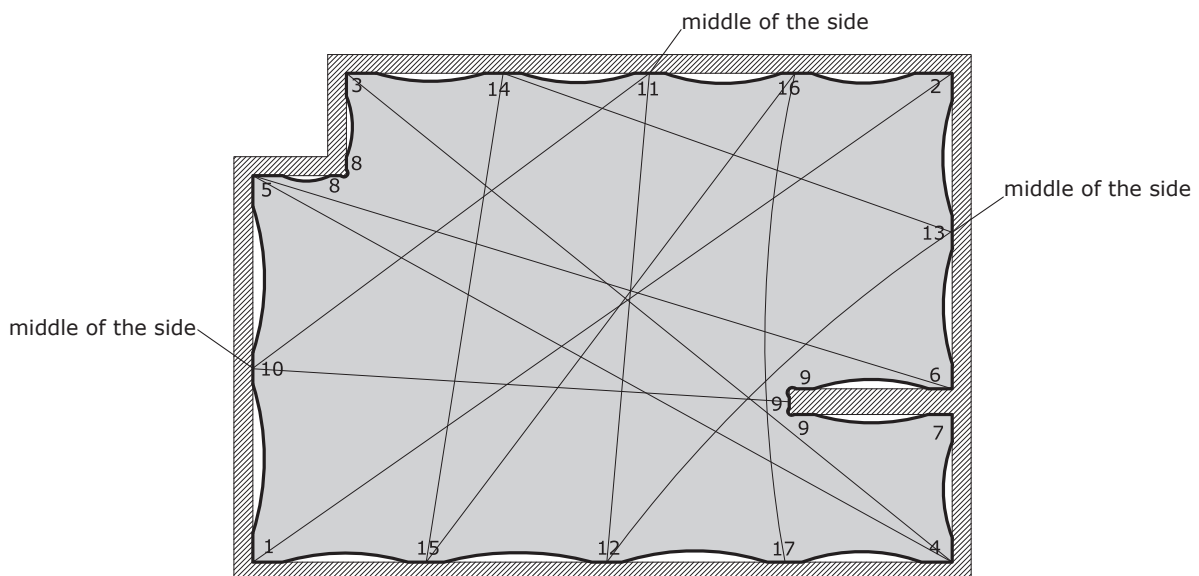

FIG. 3 | COMBINED CEILING



Due to the fact that the DPS brand and technical solutions connected to DPS stretch ceilings are covered by a patent, the following instructions are intended solely for **authorized installers of DPS stretch ceilings.**

1. All materials included in these Instructions are the exclusive copyright of GRUPA DPS sp. z o.o. in Katowice.
2. Unless specifically stated otherwise, none of the materials included in these Instructions may in any part be copied, modified, distributed, published, broadcast, recorded or used in any form with the use of any means, including electronic, mechanical, photographic or recording, without prior written consent from GRUPA DPS sp. z o.o..
3. All names, word marks, figurative marks, word/figurative marks and other markings of distinctive quality included in the Instructions are considered trademarks or other legally protected marks unless specifically stated otherwise. Using the above-mentioned marks and markings is strictly forbidden. Any copyright infringement is subject to punishment provided for in the Penal Code and the Copyright and Related Rights Act.

I. I. COMPONENTS OF DPS STRETCH CEILINGS

1. Horizontal structure made of system profiles attached to the walls at any height around the room perimeter, directly to the room ceiling or hanging loosely from any chosen part of the ceiling. It is possible to attach the profiles diagonally or vertically to obtain a plain for instance on the wall.
2. The membrane finished with a harpoon on the edges to allow for its assembly with system profiles.
3. Additional elements (optional):
 - Structure for the assembly of lighting, air conditioning, ventilation, etc
 - Reinforcement of ceiling perforation

II. PVC FILM PROPERTIES AND TESTS

The membrane is made of PVC film (1.3 m to 5.0 m wide). The film complies with European standards with respect to fire, moist and mold resistance, hygienic requirements, strength of the film itself and of the film-film and film-harpoon connections, and in some cases also to acoustic and light permeability requirements.

DPS ceilings received certificates and test results confirming compliance with the standard and obtained permission to be applied in all kinds of confined spaces. After specified time periods the ceilings are subject to tests again to guarantee that they keep the material quality standards. The Building Research Institute carries out obligatory audits at the plant that confirm compliance with the standards and unchanged production technology, which guarantees a constant quality of products.

III. TYPES AND SIZES OF MEMBRANES

1. The following types of stretch membranes are available: glossy, satine, mat, transparent, metallic, picture and perforated, according to the current offer.
2. The stretch ceiling is made of PVC film and may include connections of material: so-called „weldings”.
3. Maximum size of a ceiling covered by the warranty is 50 m² for the Standard system, 30 m² for the Slim system and 25m² for the Wall2Wall system.
4. The surface in the Standard system may, for example, have the following dimensions: 7x7m, 6x8m, 5x10m, 4x12.5m, 3x16.5m, 2x25m, 1x50m, 0,5x100m. This means that it is possible to create square-shaped membranes or more complicated membranes inscribed in a square whose side does not exceed 7m, or rectangle-shaped membranes or otherwise inscribed in a rectangle with a product of the sides that does not exceed 50 m².
5. Upon the client's request and on their sole responsibility, it is possible to make plains larger than 50 m² not covered by the warranty.
6. For printed ceilings, to keep the warranty, a single membrane cannot exceed 30m².
7. The Wall2Wall (slotless) ceilings are exclusively designed for simple geometric forms such as square, rectangle, circle. The maximum number of corners is 6 pieces per ceiling. Due to technological limitations, no indentations, overrides, angles < 45 degrees, holes, arcs (except in the case of a wheel) are made in this system. If you are in doubt about the correct application of the system, the technological capabilities must be confirmed with the manufacturer before placing an order.
8. It is possible to join different colors for one surface on condition that the connection is straight.

IV. STRETCH CEILING ASSEMBLY AND DISASSEMBLY TOOLS

Obligatory tool kit for a team of two or three people:

- 50kW gas heater with piezoelectric ignition - 1 pc
- gas cylinder with propane gas (liquefied petroleum gas is acceptable but it often freezes and has lower energy content) - 2 pcs used interchangeably
- clamps for membrane assembly - minimum of 6 pcs
- short spatula - 2 pcs
- long wide spatula - 2 pcs
- short narrow spatula - 2 pcs
- disassembly spatula - 2 pcs
- disassembly screwdriver - 2 pcs
- cotton gloves - 3 sets
- glue - 1 pc

V. REQUIRED ASSEMBLY CONDITIONS

1. Ceilings must be stored in dry closed rooms with a temperature not lower than 10 degrees Celsius and in original packaging. Recommended optimum storage temperature is about 15 degrees Celsius.
2. Unpacking may be carried out in a temperature of at least 18 degrees Celsius. The ceiling must be transported to the place of destination in a cardboard box or other rigid packaging.
3. Originally packed ceilings cannot be folded to diminish their size. A packed ceiling must be handled with proper care: it must not be laid on an uneven surface, squeezed, thrown or covered with other objects, etc.

VI. REQUIRED ASSEMBLY CONDITIONS

1. The place of ceiling assembly must be clean and especially free from dust and pollen so that the ceiling does not get dirty as any attempt to remove dust or dirt may cause scratches on the membrane.
2. It should be checked that the assembly place is empty. If there are any objects inside, they must be properly secured so that no sharp edges, elements sticking out of ladders or scaffoldings, nails, doorknobs, etc. damage the membrane.
3. Caution should be taken while working with sharp tools, such as knives, scissors, etc., so that the ceiling has no direct contact with these tools.

VII. DPS STRETCH CEILING ASSEMBLY

1. DPS stretch ceilings are intended for confined spaces both dry and humid.
2. The assembly must take place no later than 30 days after the ceiling manufacturing date as prolonged storage periods may damage this delicate product.
3. Assembly takes place in rooms where temperature before heating the membrane cannot be lower than 18 degrees Celsius. The film that the ceiling is made of is not properly flexible in lower temperatures. The lower the temperature, the stiffer and more prone to cracking the film is.
4. Each time before unpacking, the ceiling must reach a temperature of at least 18 degrees Celsius. An adaptation period of about four hours is recommended for the ceiling.
5. Before unpacking the ceiling, the clamps should be hung in the corners of the room, and in case of larger rooms also in the middle of the sides.
6. The ceiling should be unpacked with caution and the instructions on the packaging must be followed. While the ceiling is being unfolded, it should be warmed up slightly.
7. Once the ceiling is unpacked, the corner marked as the first to hang is always on top. It should be caught with the hanging clamps according to the location in the picture. Then, the unfolding should proceed and the next corners (and sides if necessary) should be hung.
8. When the ceiling hangs loosely on the clamps, the protective foam should be removed. The foam should be folded and taken out of the room.
9. The loose ceiling should be heated up with a stream of hot air generated by the heater. The activity should be conducted about one to one and a half meters (1 - 1.5m) away from the ceiling plain heating the ceiling up evenly. This allows not only for even heating of the entire membrane but in the case of Laque ceilings also for the elimination of minor wrinkles created during the packing or production process.
10. Assembly starts in any corner, followed by the corner on the diagonal, and so on. After installing the harpoon in points half a meter from one another throughout the perimeter, each section should be assembled with care taken to do it on the diagonal each time. The order of assembly is shown in the picture. The assembly is conducted with assembly spatulas.

VIII. STRETCH CEILING DISASSEMBLY

1. Disassembly of the membrane is carried out observing the same temperature conditions as in the case of assembly, but in a reverse order. Flexibility of the ceiling does not have to be as high as in the case of assembly.
2. It is prohibited to disassemble a cold ceiling – heat up the places where the harpoon is separated from the profiles as well as the corners themselves. For this purpose, a low power heater is intended – it may be electric.
3. The edge of the harpoon is pulled from the foot of the aluminum system profile with a disassembly screwdriver. The assembly spatula is slid in the slot and moved towards the corner, separating the harpoon from the profile. It is essential to separate the harpoon all the way to the end of the corner on both its sides.
4. The disassembled ceiling is packed the same way as it was delivered by the producer. It must be secured with foam separating its layers and evenly folded till it has dimensions of approximately 60x 80 cm, with folds as short as possible. It is recommended to use cardboard tubes to secure the folds.
5. A dirty ceiling must be cleaned with DPS clean products before packing.
6. If the disassembled ceiling is subject to a claim, it must be packed in a cardboard box with additional protective means, such as bubble wrap and EPS, before sending back.

TYPES OF STRETCH MEMBRANES

The main and most visible stretch ceiling component is the sheet. DPS stretch ceilings are available in a variety of textures and over a hundred color, which may all be found in the sample book.

Sheet textures are as follows:

- mat - DPS Mat
- satine - DPS Satine
- glossy - DPS Laque
- semi-transparent and transparent – DPS Transparent
- metallic – DPS Metalic
- printed – DPS Picture [based on any image of sufficient quality]
- perforated [perforation designs are provided upon customer's request] - DPS Perf
- micro-perforated – DPS Acoustic
- biopruf [of enhanced sterility] - DPS Biopruf

The standard-compliant foil is manufactured by leading producers. DPS ceilings obtained appropriate approvals, including a fire certificate, endurance test certificate, mold or chlorine resistance certificates, which guarantee their compliance with EN 14716 and 1488-CPR-0106/W standards. The product undergoes annual audits by the Building Research Institute in Poland and Germany.

DPS ceilings have bs-1, d0 and bs-2, d0 fire resistance class – the best possible for this type of products. The sheets may be 1.35 m – 5 m wide and connected to make up the surface of a ceiling. The sheets are connected using high-frequency or ultrasound welding machines [micro-welds].

The sheets have a harpoon along their edges that belongs to one of the following system profile collections:















- **Classic** - for the LC 010 profile
- **Alu** - for the Standard and Slim collection [with a visible assembly slot]
- **W2W** - for the Wall2Wall collection [with an invisible assembly slot]

Each ceiling sheet we manufacture is given a unique code and number thanks to which the assembler and the user are able to check the authenticity of the product and its warranty period.

PROFILE LIST

The STANDARD profile system is intended for ceilings whose size does not exceed 50 m².

The DPS Group shall not be held liable for misuse of STANDARD collection profiles.

PAGE	CROSS-SECTION	MODEL	CODE	DRILL IN		WAVE NOTCHES		CIRCLE NOTCHES	
				CEILING	WALL	2 cm	4 cm	2 cm	4 cm
12		LC 010	P10X00B5	X	X	X	X	X	X
13		LU 01 PVC	PP01X000	X	PP01W000	X	X	X	X
14		LU 01	A01X000	X	A01W000	A01WF20	A01WF40	A01WK20	A01WK40
16		LU 11	A110X000	X	A110W000	A110WF20	A110WF40	A110WK20	A110WK40
18		LU 04	A04X000	A04C000*	A04W000	A04WF20	A04WF40	A04WK20	A04WK40
20		LU 041	A41X000	A41C000*	A41W000	A41WF20	A41WF40	A41WK20	A41WK40
22		LS 044	A44X000	A44C000	X	A44CF20	A44CF40	X	X
24		LSEC 44	A44XECO	X	X	X	X	X	X
26		LSIC 44	A44XICO	X	X	X	X	X	X
28		PSN-LMP	LMP	X	X	X	X	X	X
28		PSN-LMP 01	LMP01	X	X	X	X	X	X
28		PSN-LMP 02	LMP02	X	X	X	X	X	X
30		PSN 9145	91.45	X	X	X	X	X	X
32		ALX1	ALX1	X	X	X	X	X	X
34		LU-KL	S04X000	X	X	X	X	X	X

* profiles available on request

LC 010

A classic profile used when a margin in the form of a cornice is required on the edge. For decorative purposes, the profile may be hidden behind decorative molding.

The profile makes it possible to disassemble the ceiling sheet without the necessity to remove the molding.

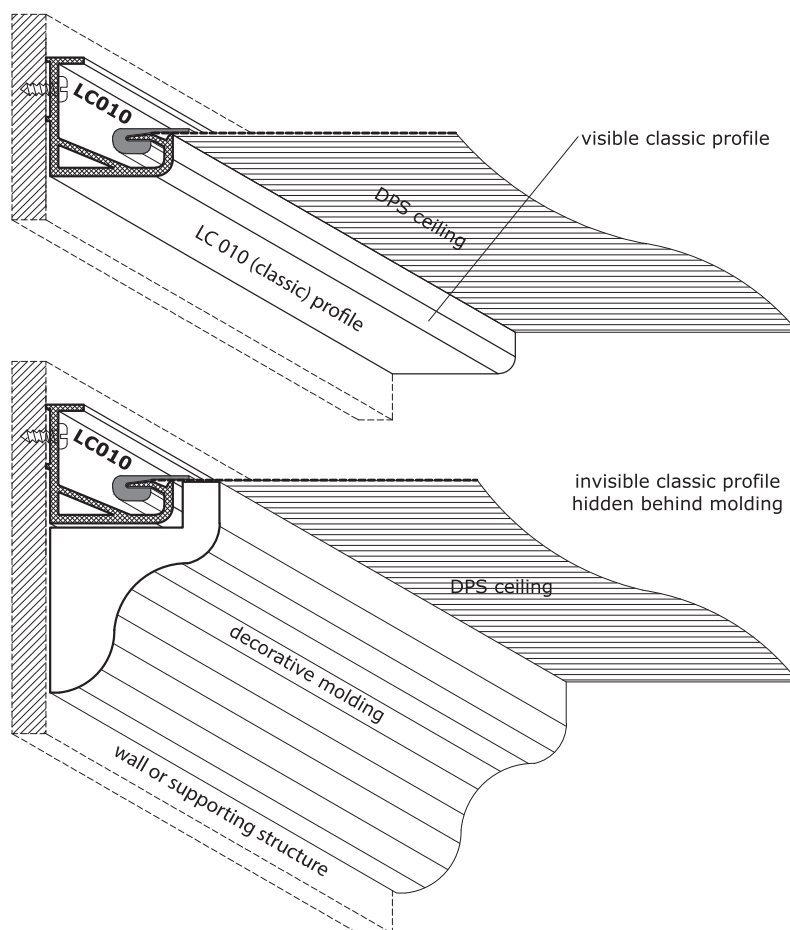
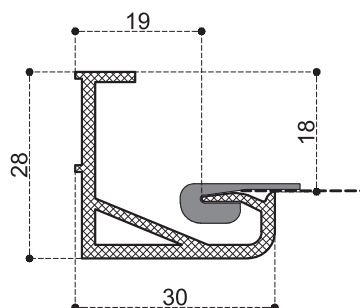

model:	LC 010 [PVC]
product code:	P10X00B5
trading length:	2.5 lm
weight:	0.272 kg/lm
assembly holes:	none
notches:	none
assembly:	wall (W)
compatibility:	white Classic harpoon

LU 01 [PVC]

An exact copy of the aluminum LU 01 profile, made of PVC.

One advantage of this product is its ability to bend in order to achieve curves and circles with no need for cutting.

It is connectible to the LU01 profile [aluminum] by means of a PLLU connector.

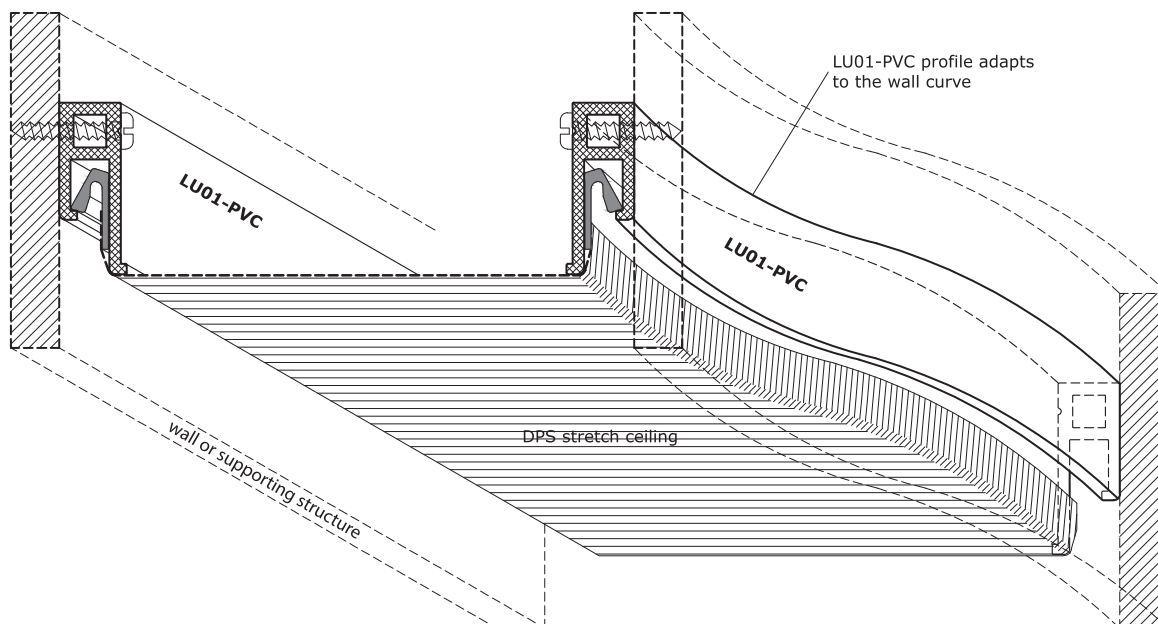
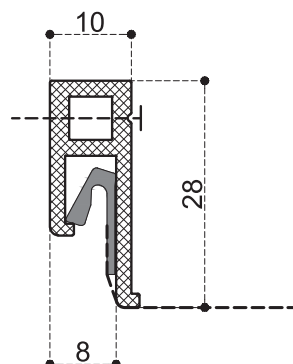

model:	LU 01 [PVC]	
product code:	PP01X000	PP01W000
trading length:	2.5 ml	2.5 lm
weight:	0.187 kg/ml	0.178 kg/lm
assembly holes:	none	Ø 6 every 20 cm
notches:	none	none
assembly:	wall (W)	
compatibility:	alu white harpoon, alu black harpoon	

LU 01

One of basic profiles in the STANDARD system, attached to the room walls. Mainly used for large or complex ceilings. A square hole in the upper part of the profile is intended for the attachment of a PLLU connector that guarantees a straight line of the ceiling edge where two profiles connect.

A notched version allows you to obtain a horizontal curve effect [circle] and a three-dimensional curve effect [wave].

Upon request, the profile may be powder coated or anodized.

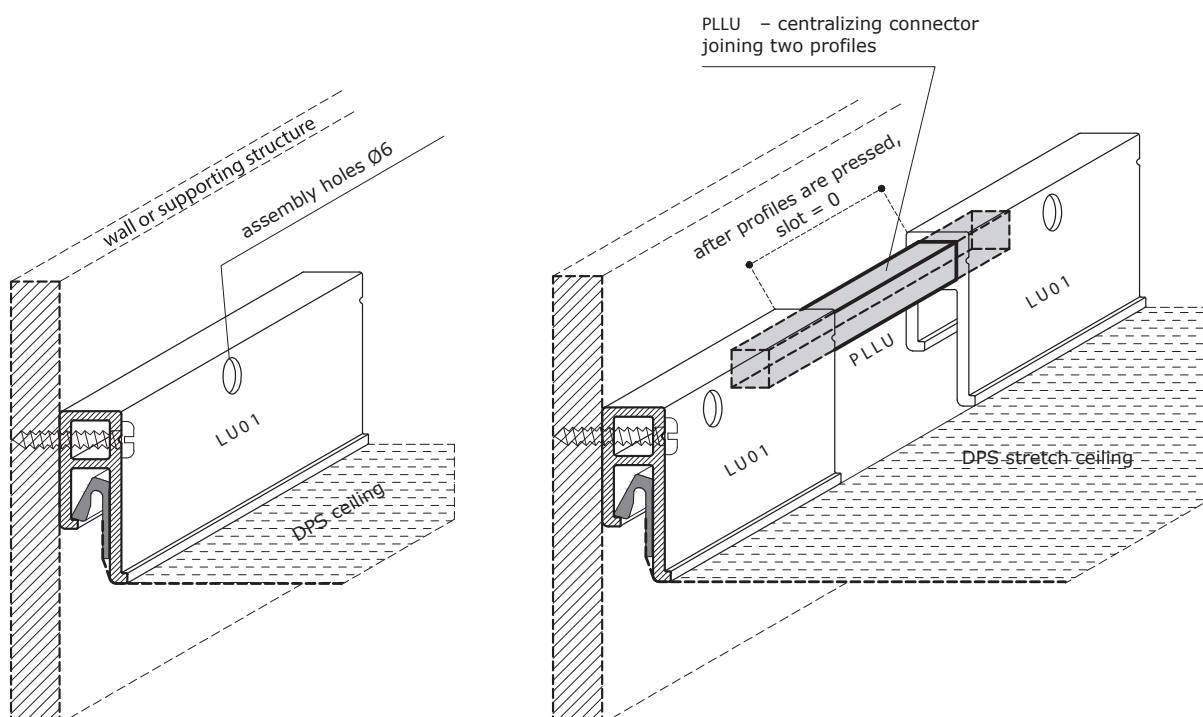
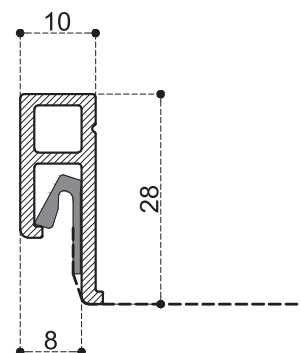

model:	LU 01 [aluminium 6060 T6]					
product code:	A01X000	A01W000	A01WF20	A01WF40	A01WK20	A01WK40
trading length:	2.5 lm	2.5 lm	2.5 lm	2.5 lm	2.5 lm	2.5 lm
weight:	0.304 kg/lm	0.295 kg/lm	0.272 kg/lm	0.278 kg/lm	0.281 kg/lm	0.289 kg/lm
assembly holes:	none	Ø 6 every 20 cm	Ø 6 every 20 cm	Ø 6 every 20 cm	Ø 6 every 20 cm	Ø 6 every 20 cm
notches:	none	none	every 2 cm/wave	every 4 cm/wave	every 2 cm/circle	every 4 cm/circle
assembly:	wall (W)					
compatibility:	alu white harpoon, alu black harpoon					

FLAT CEILING WITH CONVEX CURVE

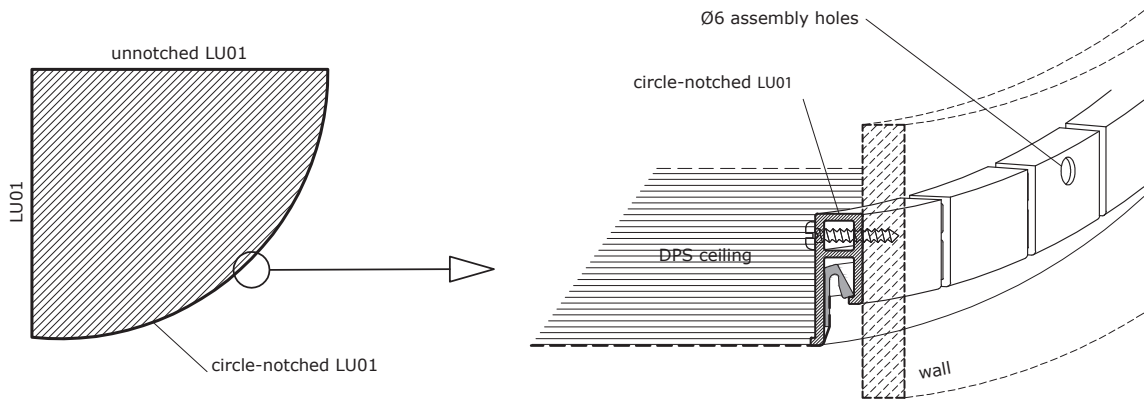

THREE-DIMENSIONAL CEILING WITH WAVE

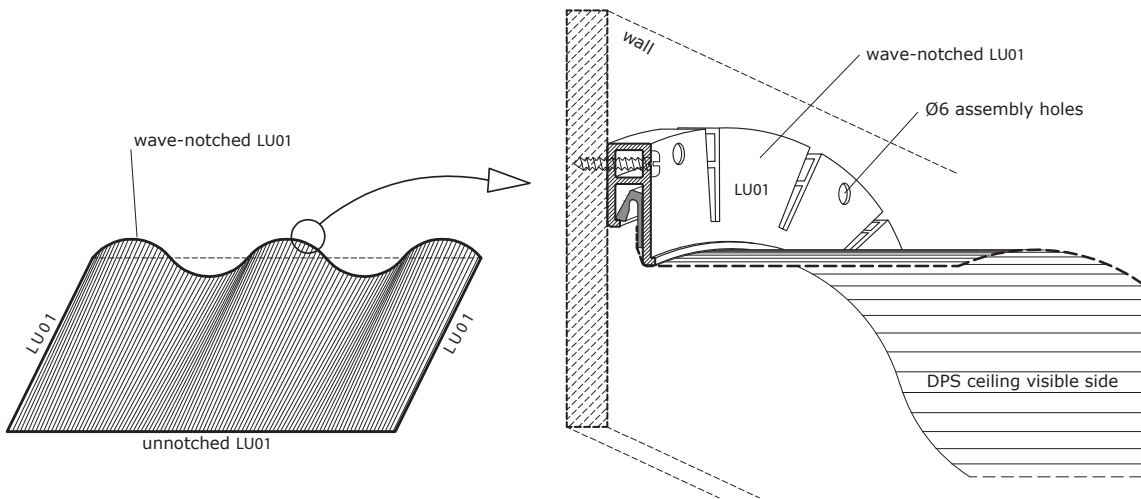

FLAT CEILING WITH CONCAVE CURVE

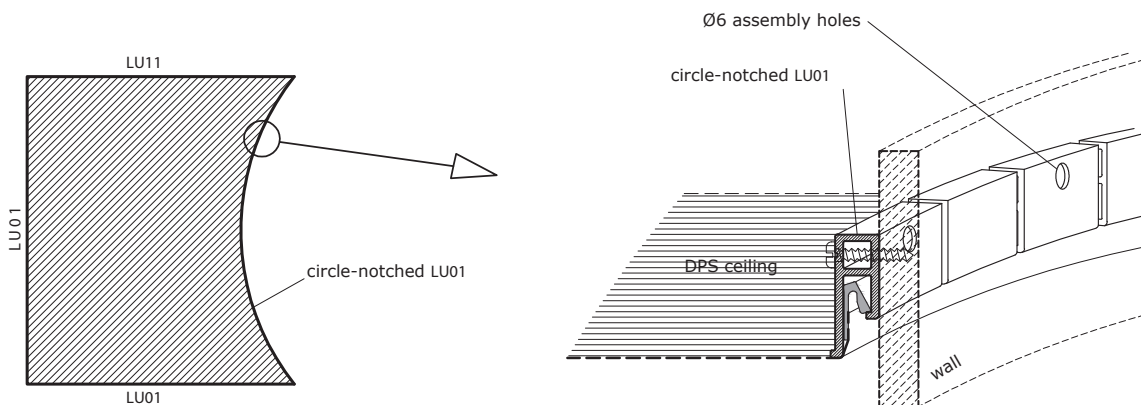

LU 11

A profile attached to the room walls. Mainly used for large ceilings. A square hole in the upper part of the profile is intended for the attachment of a PLLU connector that guarantees a straight line of the ceiling edge where two profiles connect.

A notched version allows you to obtain a horizontal curve effect [circle] and a three-dimensional curve effect [wave].

The profile has a catch enabling the attachment of a plug that fills in the technological slot between the wall and the ceiling edge [FIG. 1, 2].

Upon request, the profile may be powder coated or anodized.

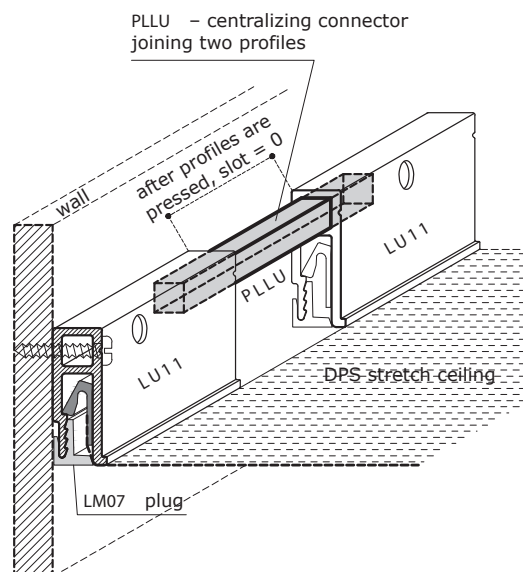
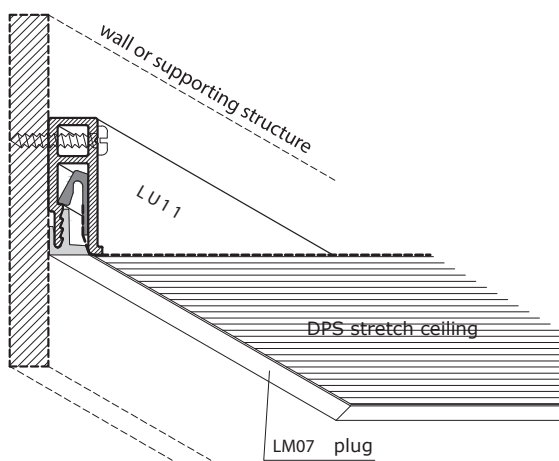
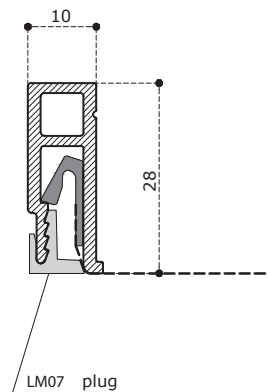

model:	LU 11 [aluminium 6060 T6]					
product code:	A110X000	A110W000	A110WF20	A110WF40	A110WK20	A110WK40
trading length:	2.5 lm	2.5 lm	2.5 lm	2.5 lm	2.5 lm	2.5 lm
weight:	0.332 kg/lm	0.325 kg/lm	0.310 kg/lm	0.314 kg/lm	0.312 kg/lm	0.318 kg/lm
assembly holes:	none	Ø 6 every 20 cm	Ø 6 every 20 cm	Ø 6 every 20 cm	Ø 6 every 20 cm	Ø 6 every 20 cm
notches:	none	none	every 2 cm/wave	every 4 cm/wave	every 2 cm/circle	every 4 cm/circle
assembly:	wall (W)					
compatibility:	alu white harpoon, alu black harpoon					

FLAT CEILING WITH CONVEX CURVE

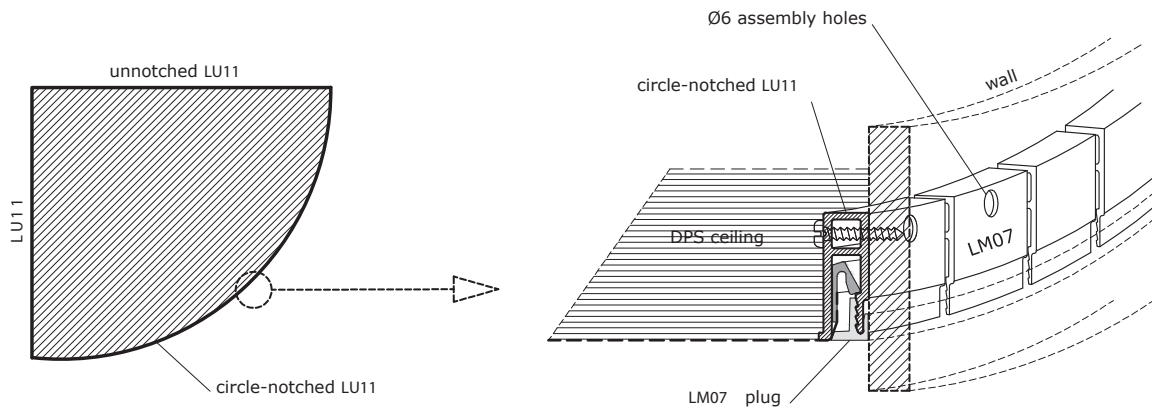

THREE-DIMENSIONAL CEILING WITH WAVE

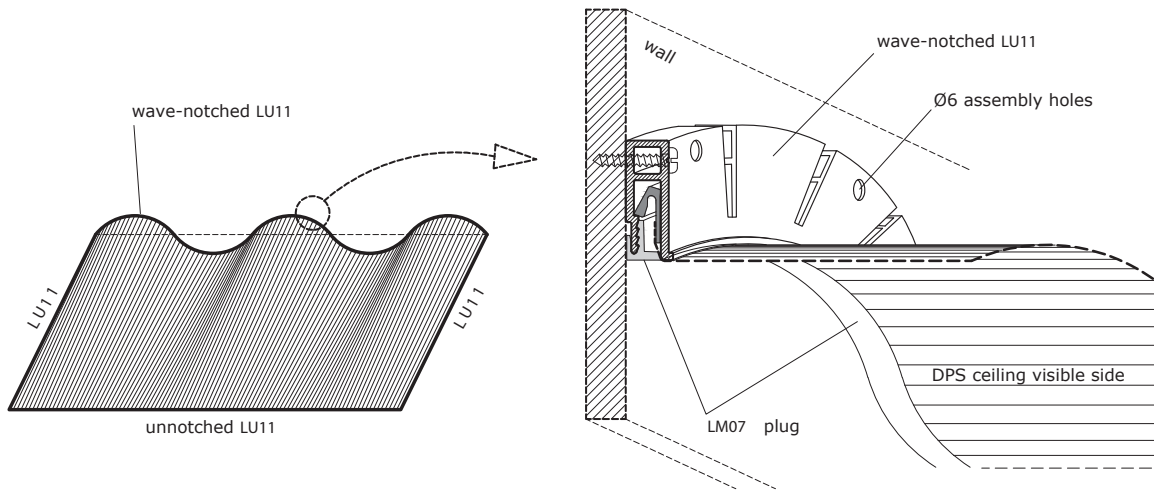

FLAT CEILING WITH CONCAVE CURVE

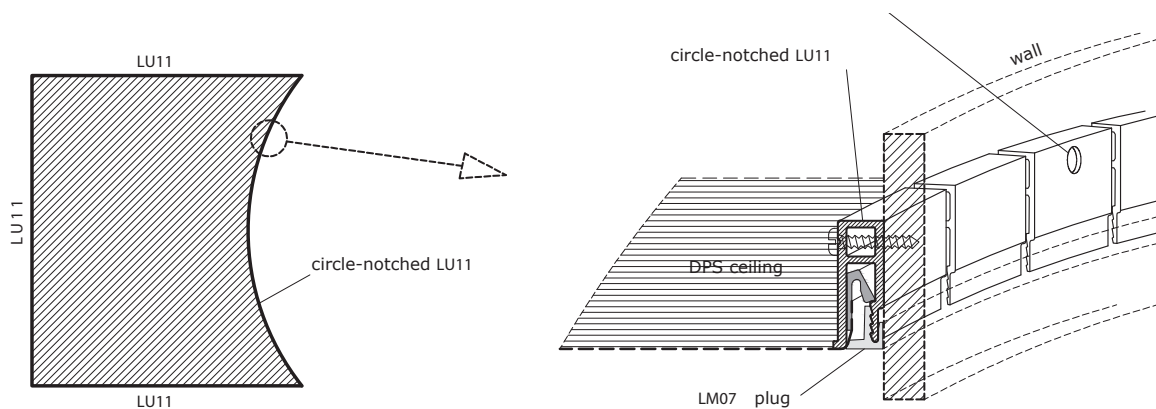

LU 04

A basic general-purpose assembly profile in the STANDARD system. Its versatility lies in the possibility to attach it both to walls and ceilings as well as to use it as a separator for sheets.

A notched version allows you to obtain a horizontal curve effect [circle] and a three-dimensional curve effect [wave].

The profile has a catch enabling the attachment of a plug that fills in:

1. the technological slot between the wall and the ceiling edge [FIG. 1]
2. the separator [FIG. 2].

A square hole in the upper part of the profile is intended for the attachment of a PLLU connector that guarantees a straight line of the ceiling edge where two profiles connect.

Upon request, the profile may be powder coated or anodized.

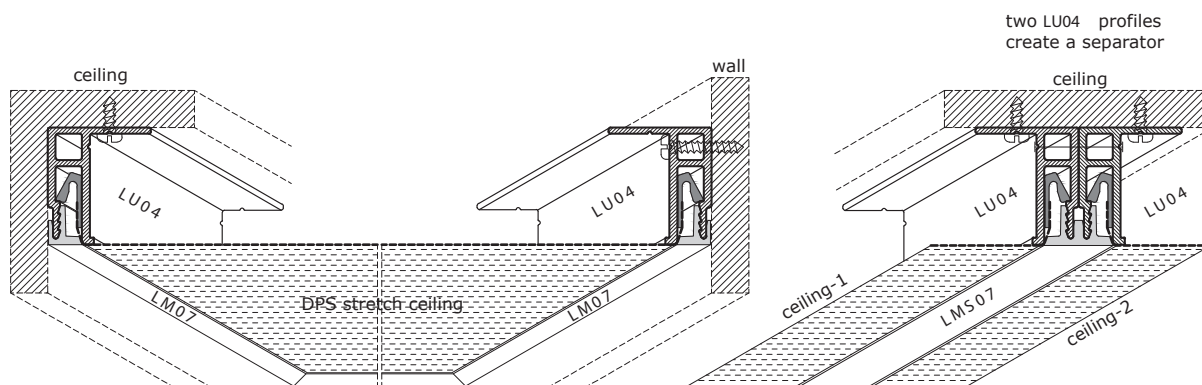
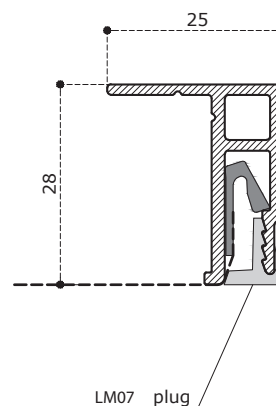

model:	LU 04 [aluminium 6060 T6]					
product code:	A04X000	A04W/C000	A04WF20	A04WF40	A04WK20	A04WK40
trading length:	2.5 lm	2.5 lm	2.5 lm	2.5 lm	2.5 lm	2.5 lm
weight:	0.391 kg/lm	0.382 kg/lm	0.360 kg/lm	0.370 kg/lm	0.364 kg/lm	0.373 kg/lm
assembly holes:	none	Ø 6 every 20 cm	Ø 6 every 20 cm	Ø 6 every 20 cm	Ø 6 every 20 cm	Ø 6 every 20 cm
notches:	none	none	every 2 cm/wave	every 4 cm/wave	every 2 cm/circle	every 4 cm/circle
assembly:	wall (W) / ceiling (C)					
compatibility:	alu white harpoon, alu black harpoon					

WAVE-TYPE THREE-DIMENSIONAL CEILING

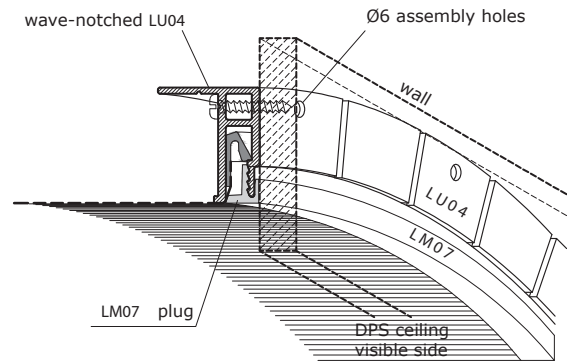
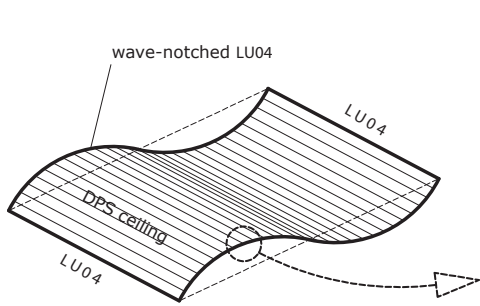

This method of making bent lines is also identical when LU04 profiles are used dually - in the form of a separator.

FLAT CIRCLE- OR ELLIPSE-TYPE CEILING

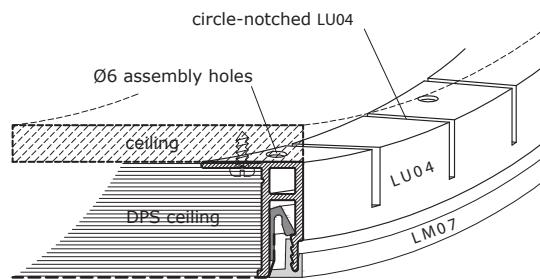
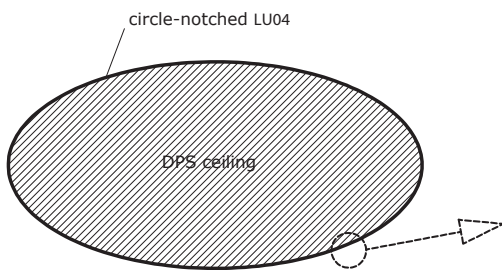

This method of making bent lines is also identical when LU04 profiles are used dually - in the form of a separator.

CIRCUMVENTION OF ROUND PILLAR

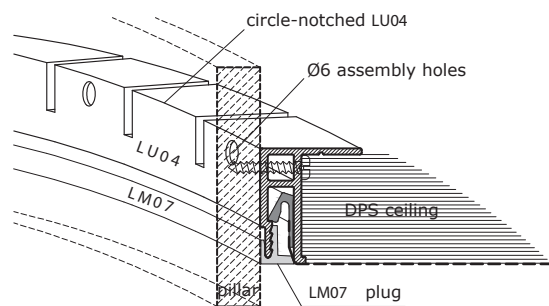
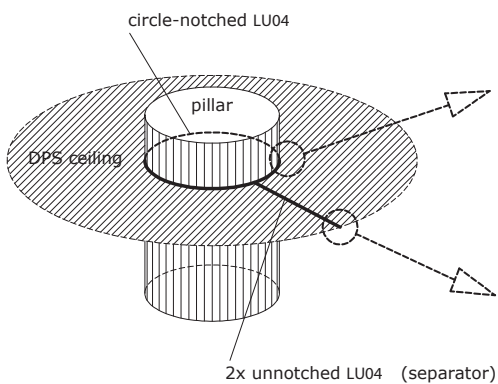

This method of making bent lines is also identical when LU04 profiles are used dually - in the form of a separator together with double plug LMS07.

LU 041

A general-purpose assembly profile in the STANDARD system collection. May be attached to both walls and ceilings.

A notched version allows you to obtain a horizontal curve effect [circle] and a three-dimensional curve effect [wave].

The profile does not have a catch enabling the attachment of a plug.

A square hole in the upper part of the profile is intended for the attachment of a PLLU connector that guarantees a straight line of the ceiling edge where two profiles connect.

Upon request, the profile may be powder coated or anodized.

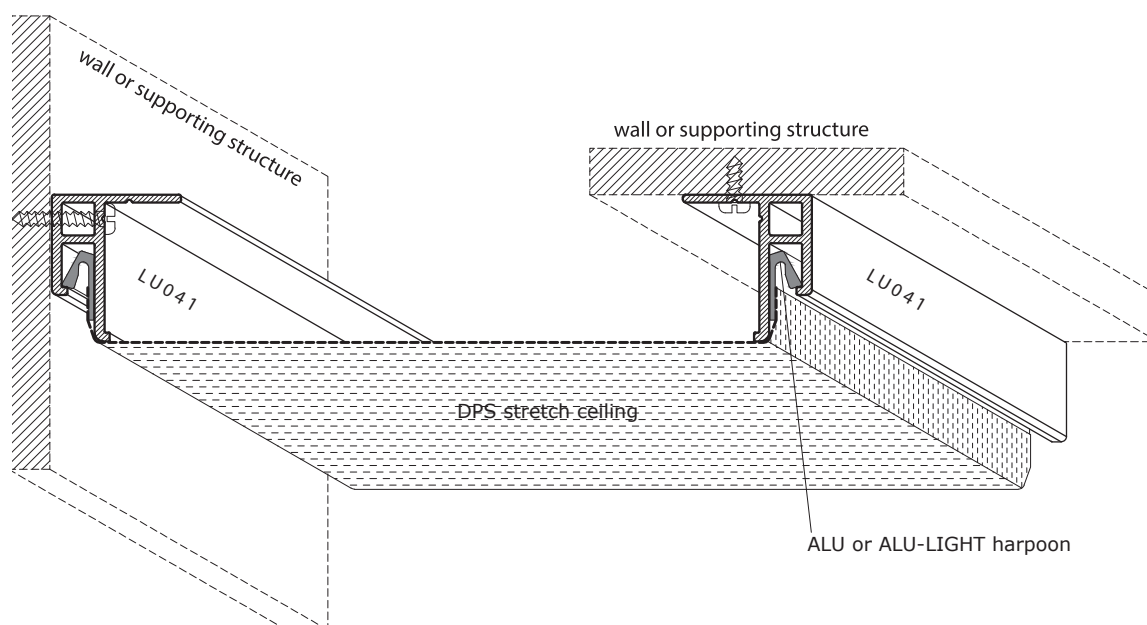
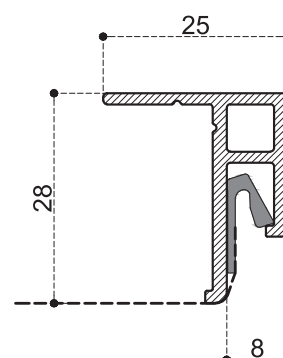

model:	LU 041 [aluminium 6060 T6]					
product code:	A41X000	A41W/C000	A41WF20	A41WF40	A41WK20	A41WK40
trading length:	2.5 lm	2.5 lm	2.5 lm	2.5 lm	2.5 lm	2.5 lm
weight:	0.362 kg/lm	0.351 kg/lm	0.332 kg/lm	0.340 kg/lm	0.338 kg/lm	0.346 kg/lm
assembly holes:	none	Ø 6 every 20 cm	Ø 6 every 20 cm	Ø 6 every 20 cm	Ø 6 every 20 cm	Ø 6 every 20 cm
notches:	none	none	every 2 cm/wave	every 4 cm/wave	every 2 cm/circle	every 4 cm/circle
assembly:	wall (W) / ceiling (C)					
compatibility:	alu white harpoon, alu black harpoon					

COLUMN-SHAPED THREE-DIMENSIONAL CEILING

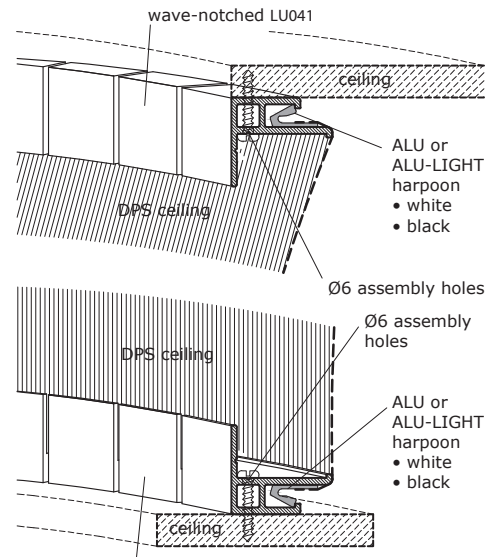
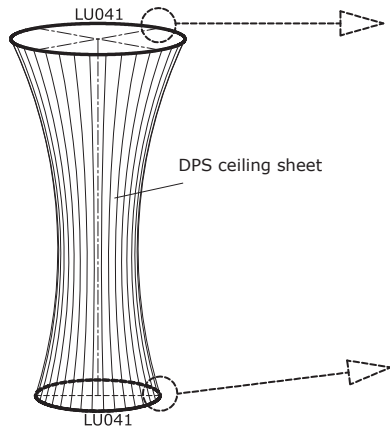

THREE-DIMENSIONAL ARCH CEILING

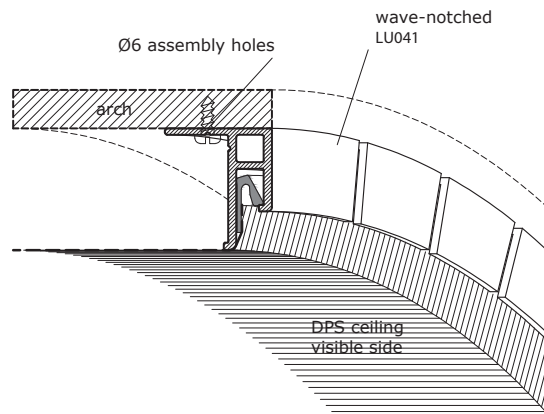
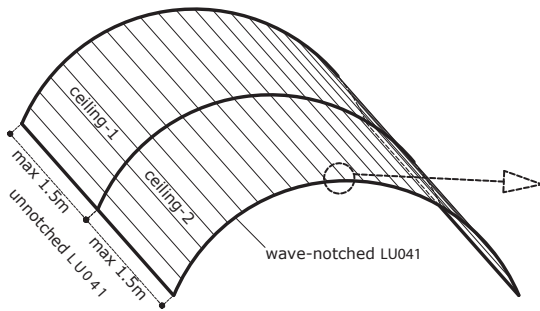

FLAT CEILING IN ANY SHAPE

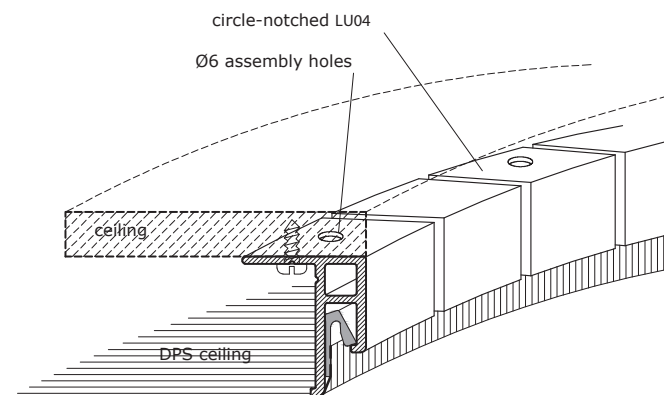
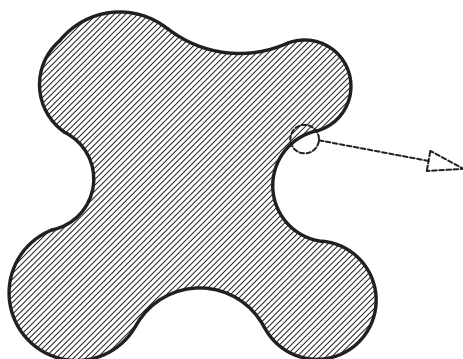

LS 044

A separating profile used to join stretch ceiling sheets.

Holes in the upper part of the profile are intended for the attachment of a PLLU connector that guarantees a straight line of the ceiling edge where two profiles connect.

A notched version allows you to obtain a horizontal curve effect [circle] and a three-dimensional curve effect [wave].

Upon request, the profile may be powder coated or anodized.

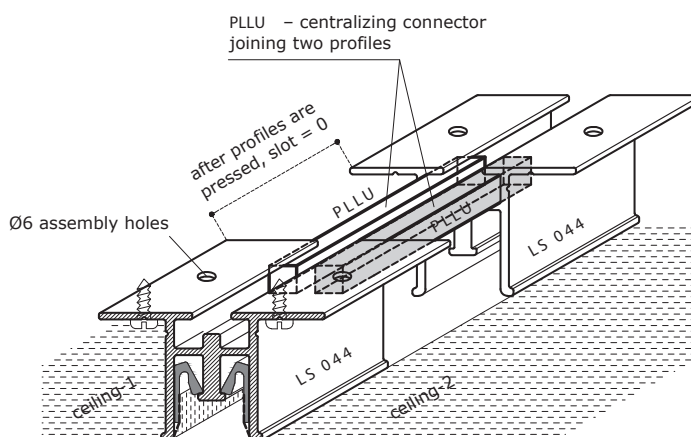
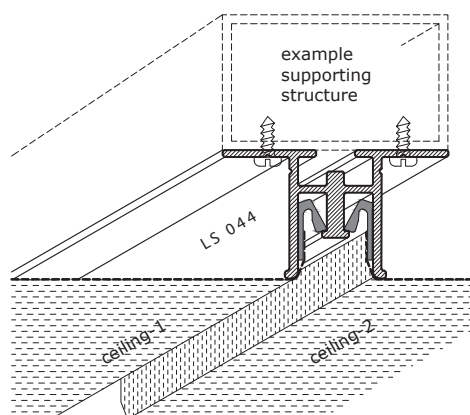
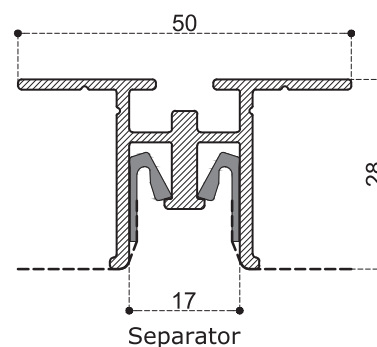

model:	LS 044 [aluminium 6060 T6]			
product code:	A44X000	A44C000	A44CF20	A44CF40
trading length:	2.5 lm	2.5 lm	2.5 lm	2.5 lm
weight:	0.650 kg/lm	0.638 kg/lm	0.594 kg/lm	0.612 kg/lm
assembly holes:	none	Ø 6 co 20 cm	Ø 6 every 20 cm	Ø 6 every 20 cm
notches:	none	none	every 2 cm/wave	every 4 cm/wave
assembly:	ceiling (C)			
compatibility:	alu white harpoon, alu black harpoon			

ARCH CEILINGS

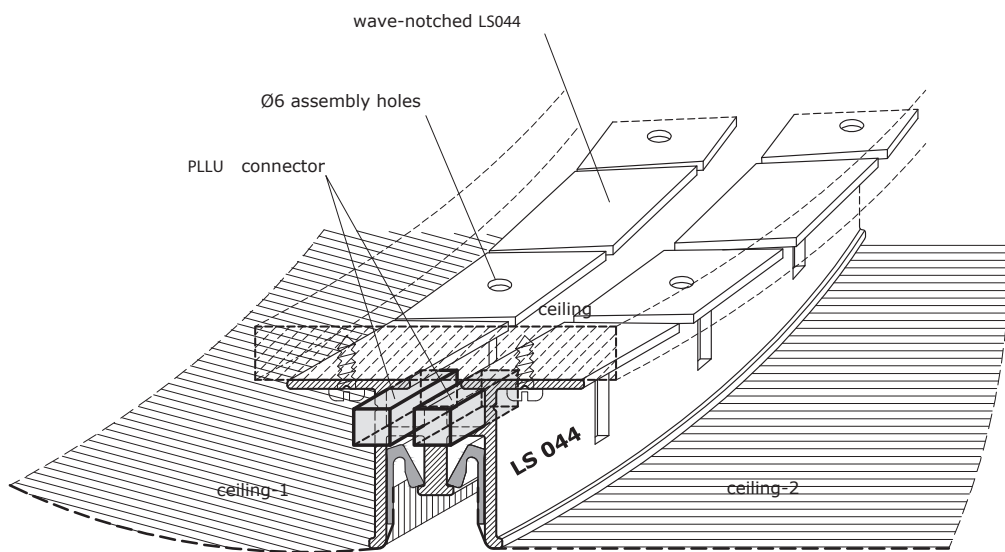
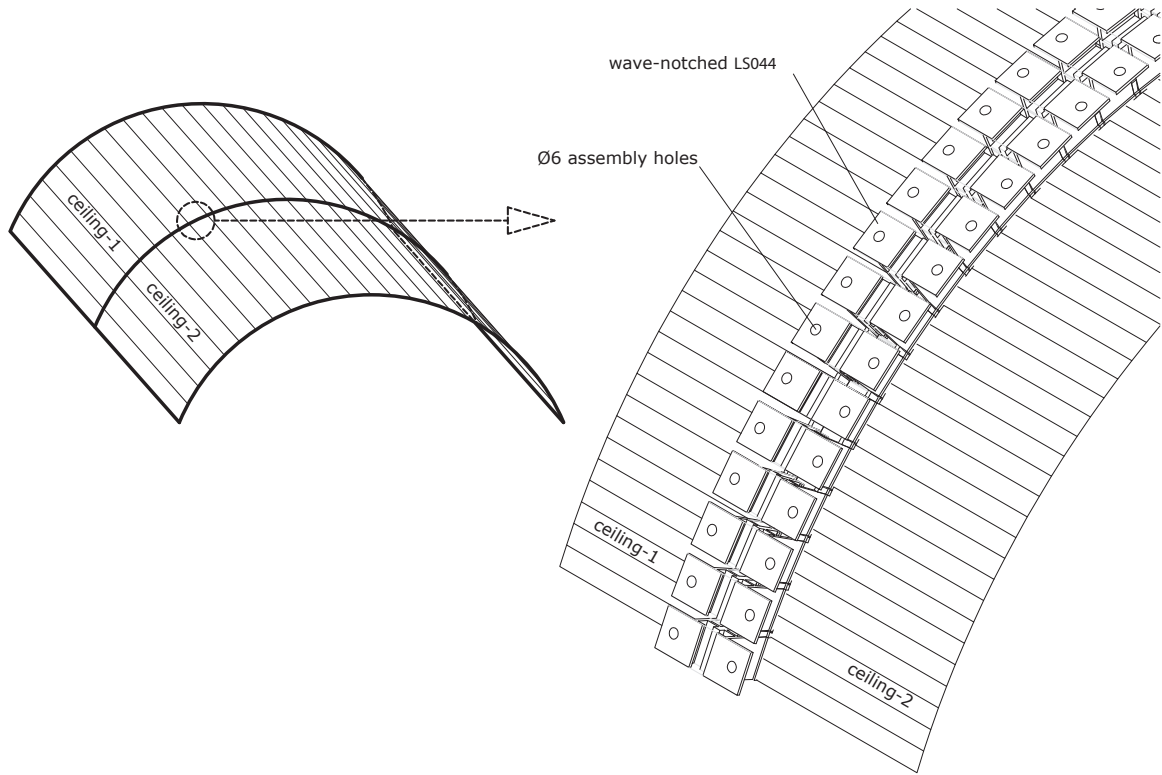

LSEC 44

A separating corner profile used to join stretch ceiling sheets at an angle from 180° to 270°. Combined with other profiles, it can be used to create three-dimensional elements.

Holes in the upper part of the profile are intended for the attachment of a PLLU connector that guarantees a straight line of the ceiling edge where two profiles connect.

Upon request, the profile may be powder coated or anodized.

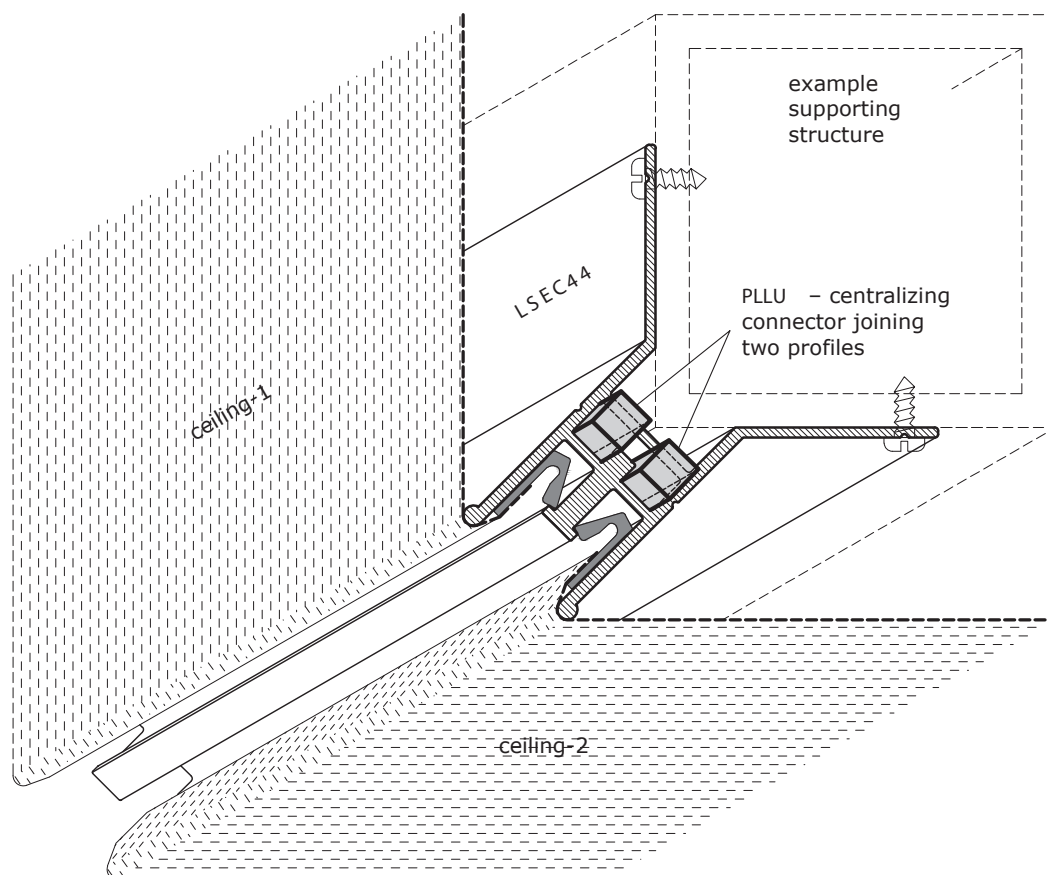
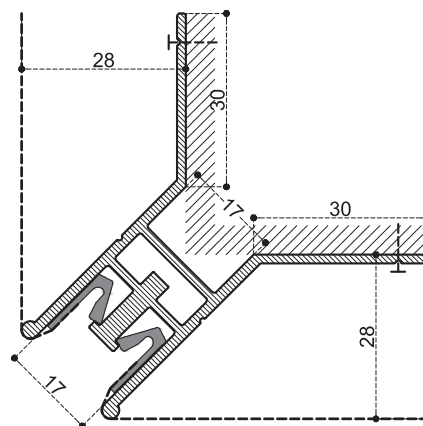

model:	LSEC 44 [aluminium 6060 T6]
product code:	A44XECO
trading length:	2.5 lm
weight:	0.912 kg/lm
assembly holes:	none
notches:	none
assembly:	wall (W)/ support structure
compatibility:	alu white harpoon, alu black harpoon

CEILING JOIST COVER

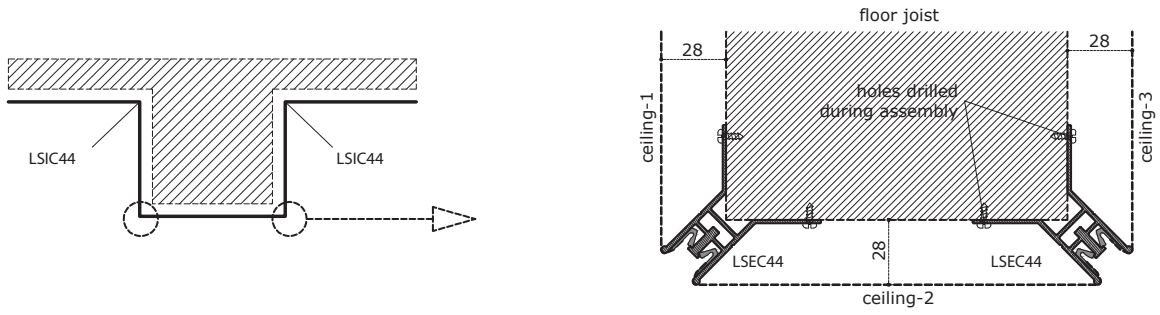

DECORATIVE COVER FOR PILLAR, COLUMN, ETC.

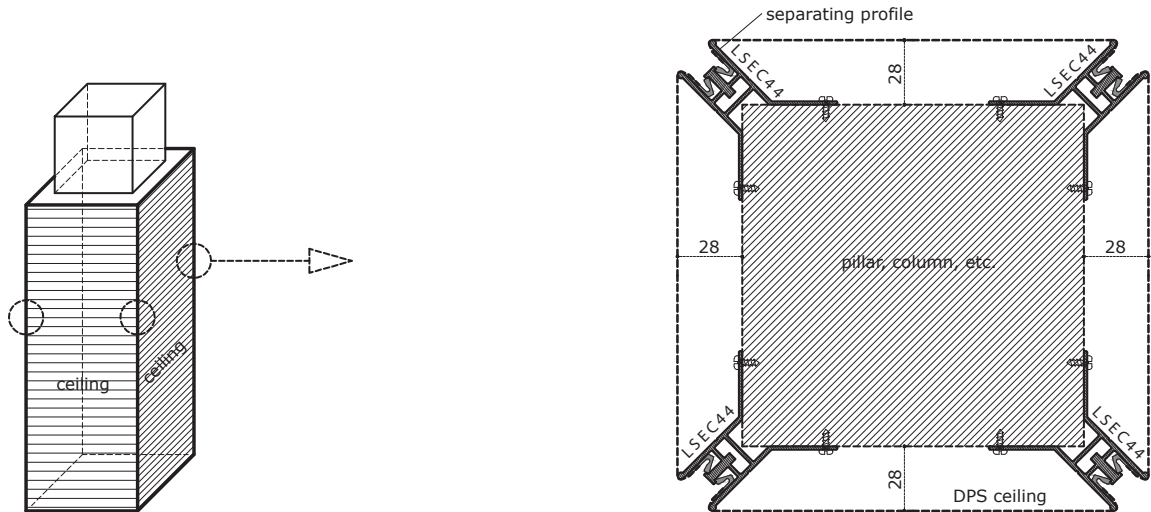

MULTI-LEVEL SHEETS

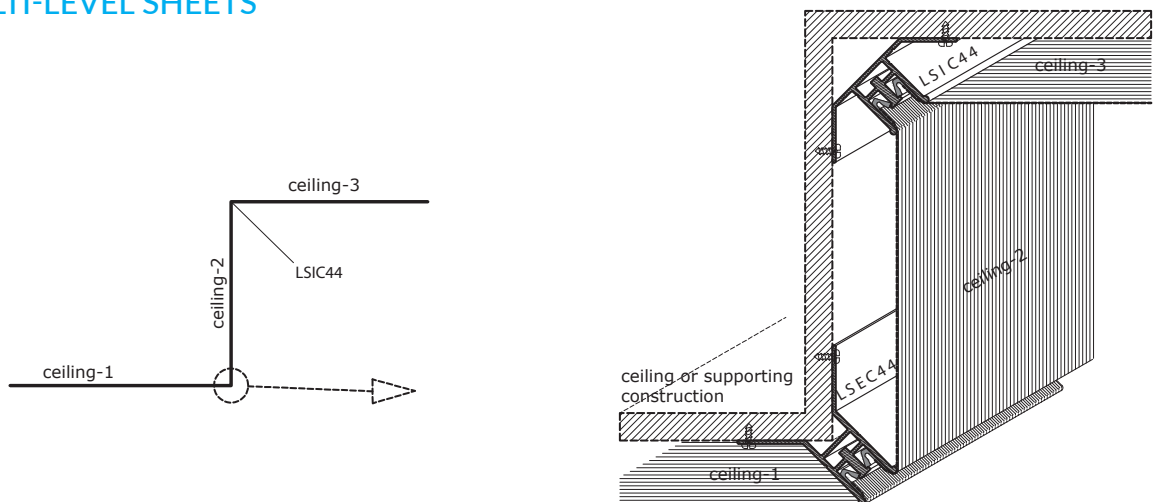

LSIC 44

A separating internal corner profile used to join stretch ceiling sheets at an angle from 90° to 180° or in combination with other profiles to create multi-level or three-dimensional elements.

Holes in the upper part of the profile are intended for the attachment of a PLLU connector that guarantees a straight line of the ceiling edge where two profiles connect.

Upon request, the profile may be powder coated or anodized.

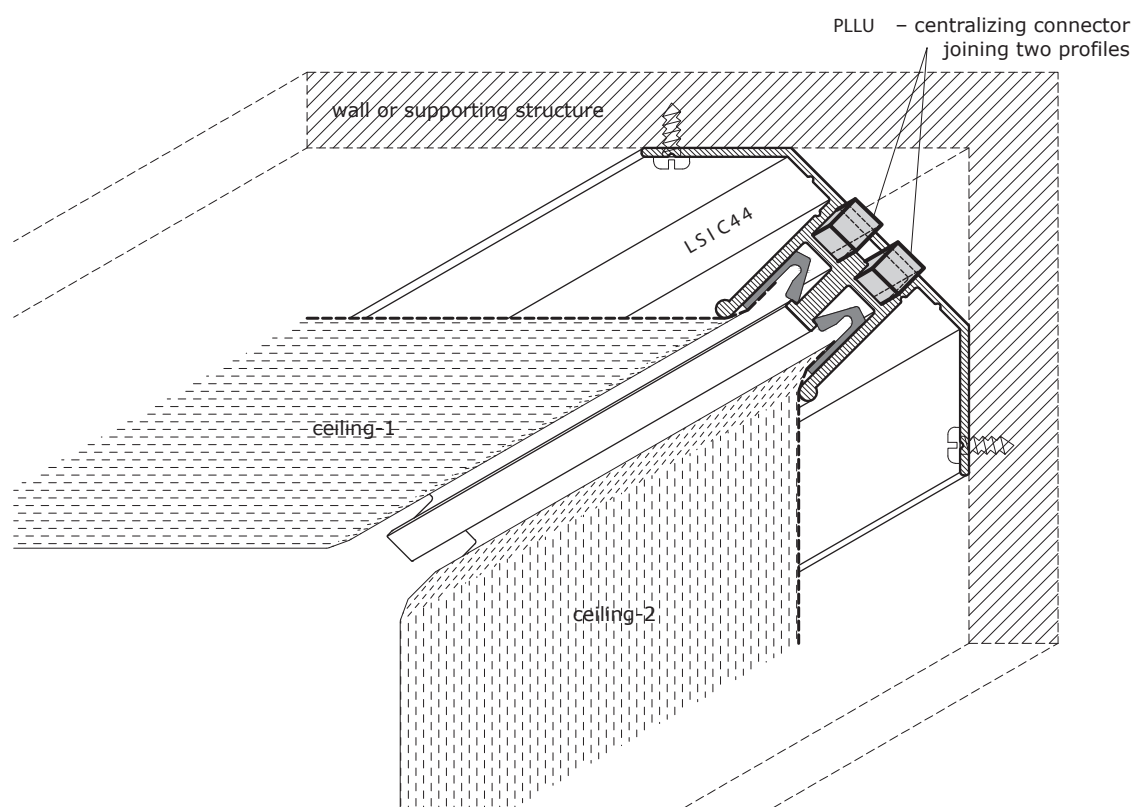
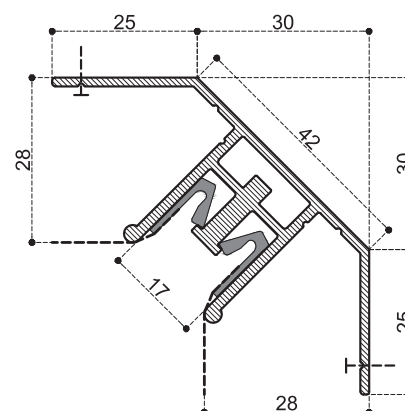

model:	LSIC 44 [aluminium 6060 T6]
product code:	A44XIC0
trading length:	2.5 lm
weight:	0.859 kg/lm
assembly holes:	none
notches:	none
assembly:	wall (W) + ceiling (C) / support structure
compatibility:	alu white harpoon, alu black harpoon

COMBINING VERTICAL AND HORIZONTAL SHEETS

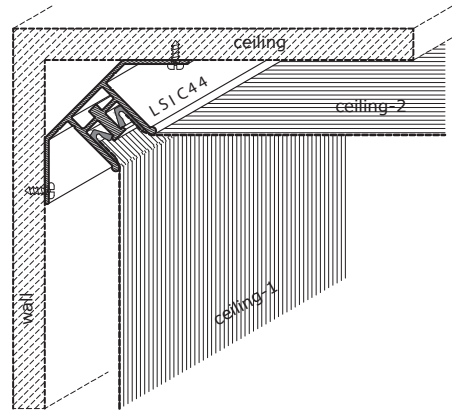
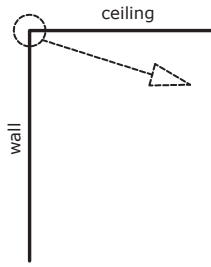

COVER FOR CEILING JOIST, AIR DUCT, TUBES, ETC.

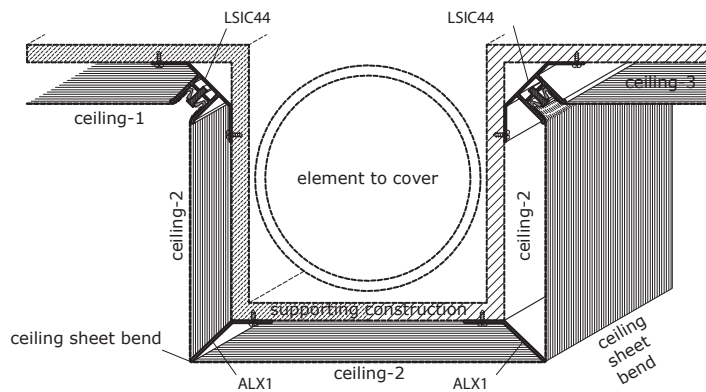
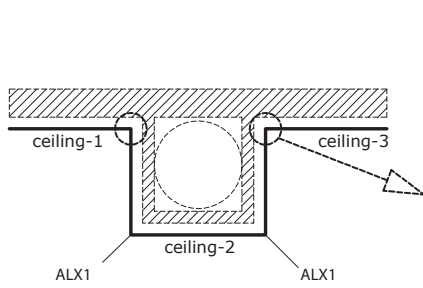

CEILING SHEET OFFSET

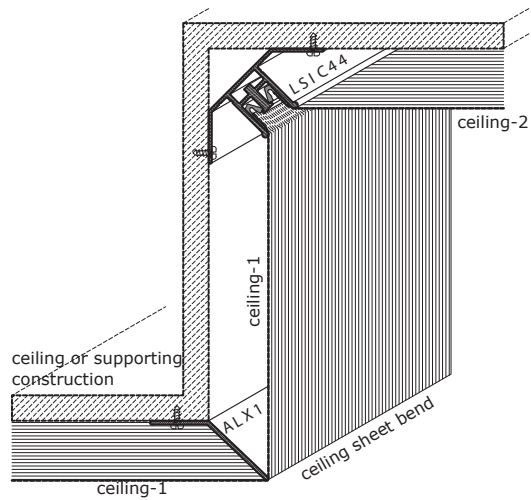
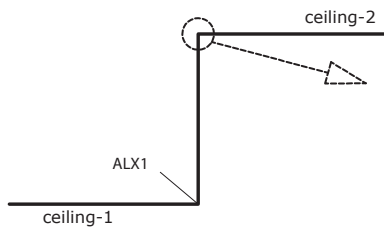

PSN LMP

A self-supporting or ceiling-attached profile.

Used for one of the following:

- light/advertising panels [FIG. 1, 2]
- acoustic panels [FIG. 3]
- decorative panels
- individual elements of an island display

Upon request, the profile may be anodized or powder coated.

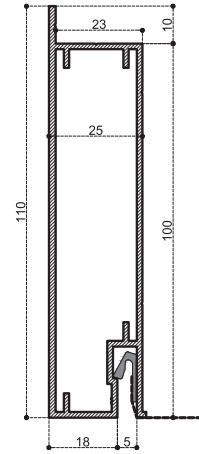
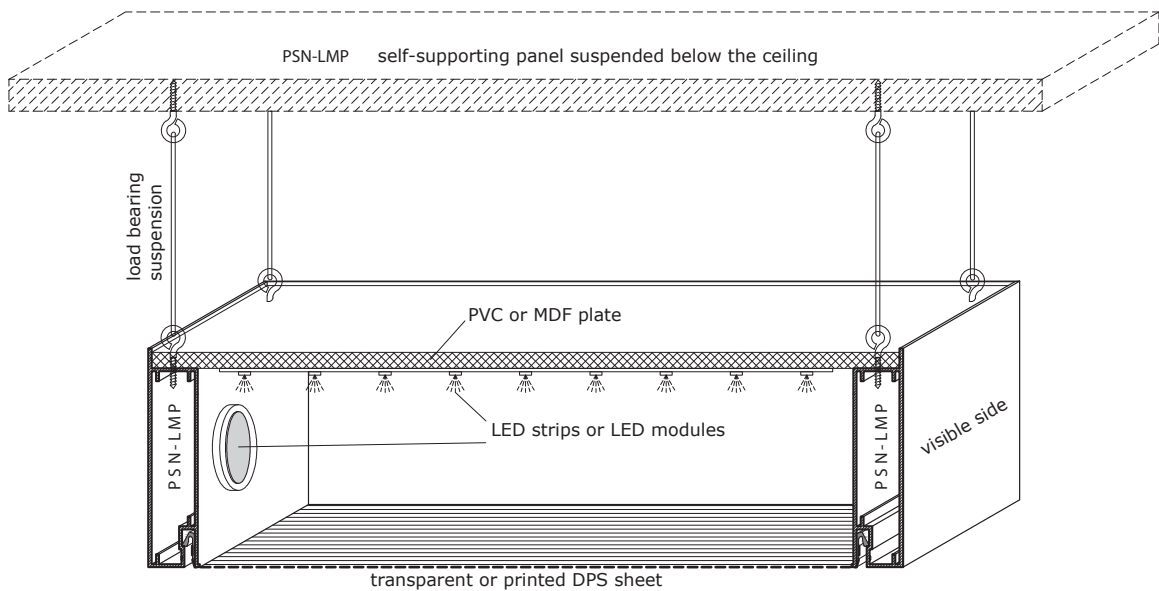

FIG. 1 | LIGHT OR ADVERTISING PANEL



model:	PSN-LMP	PSN-LMP 01	PSN-LMP 02
product code:	LMP	LMP01	LMP02
material:	aluminium 6060 T6	aluminium 6060 T6	aluminium 6060 T6
trading length:	5.0 lm	upon request	upon request
weight:	1.281 kg/lm	1.506 kg/lm	1.502 kg/lm
assembly holes:	none	none	none
notches:	none	none	none
bending*:	yes	yes	yes
compatibility:	alu harpoon	alu harpoon + W2W	alu harpoon
comments:	*possible curves with radius over 3m		

FIG. 2 | LIGHT OR ADVERTISING PANEL

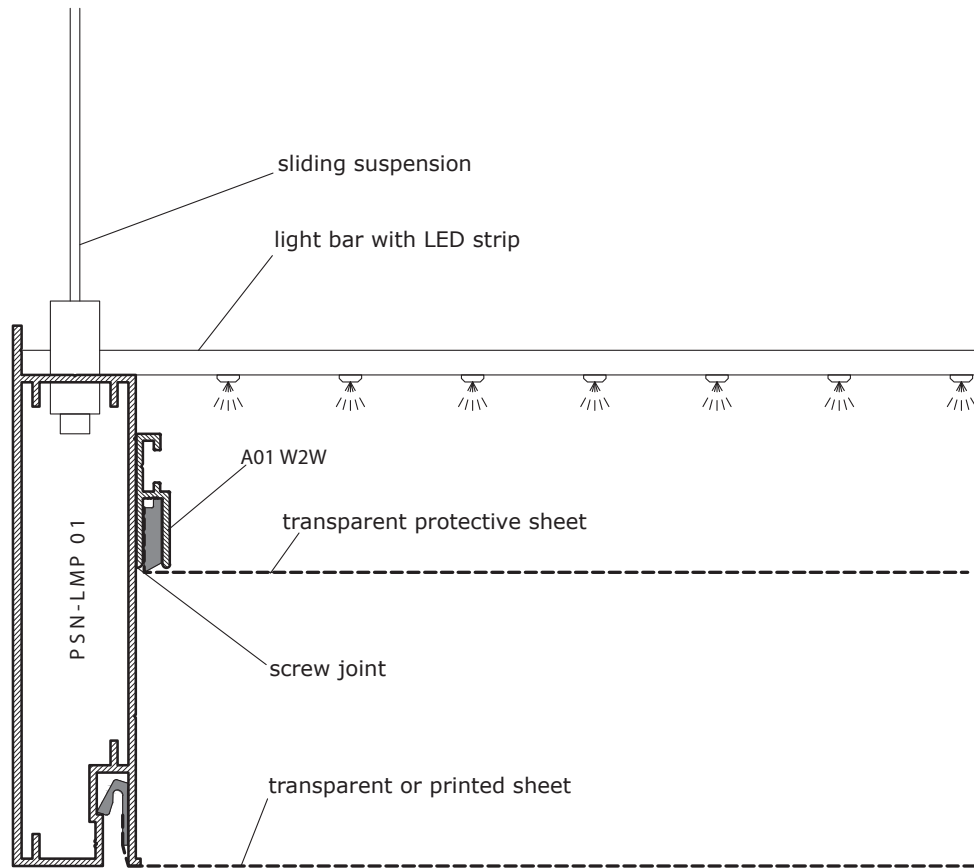
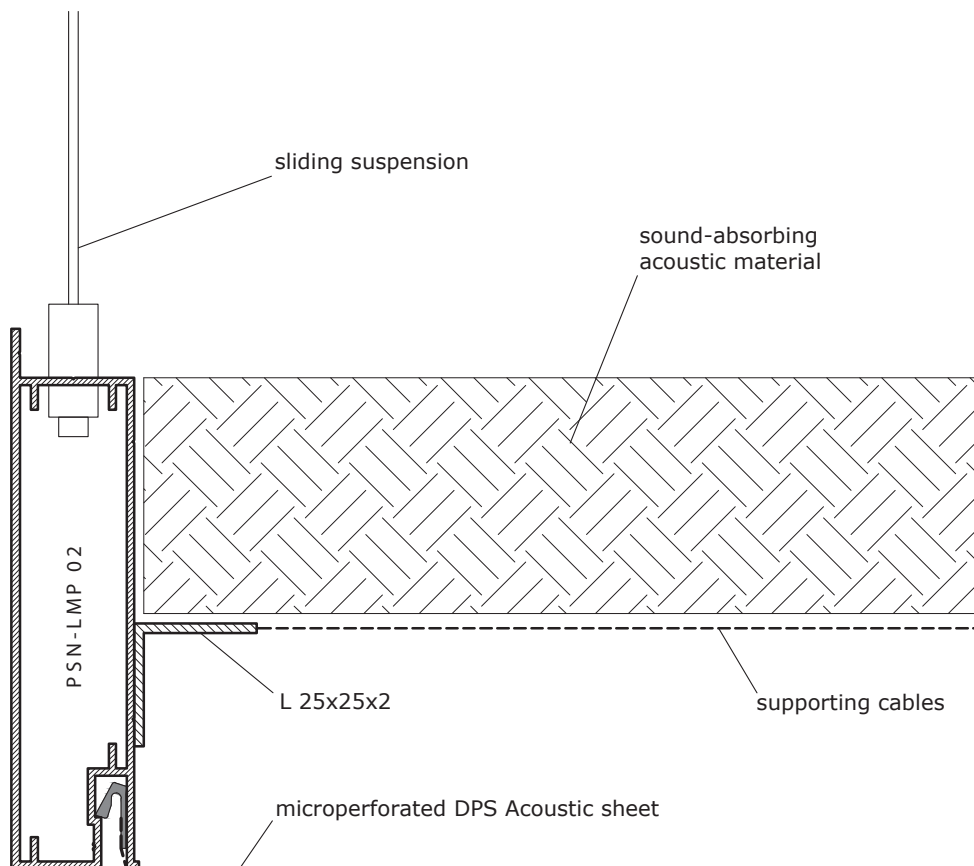

FIG. 3 | ACOUSTIC PANEL



PSN 9145

A high-rigidity profile, designed for the construction of free-hanging square or rectangular elements as a frame for:

- large-format lighting [fig.1]
- acoustic panels [fig.2]
- separate ceiling panels [fig.3]
- integrated panels [fig.4]
- advertising and decorative panels [fig.5].

Upon request, the profile may be powder coated or anodized.

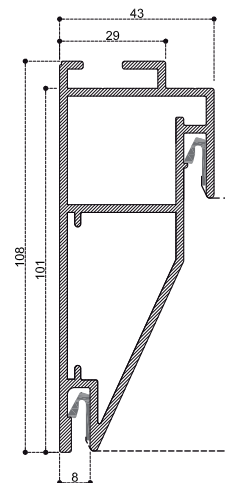
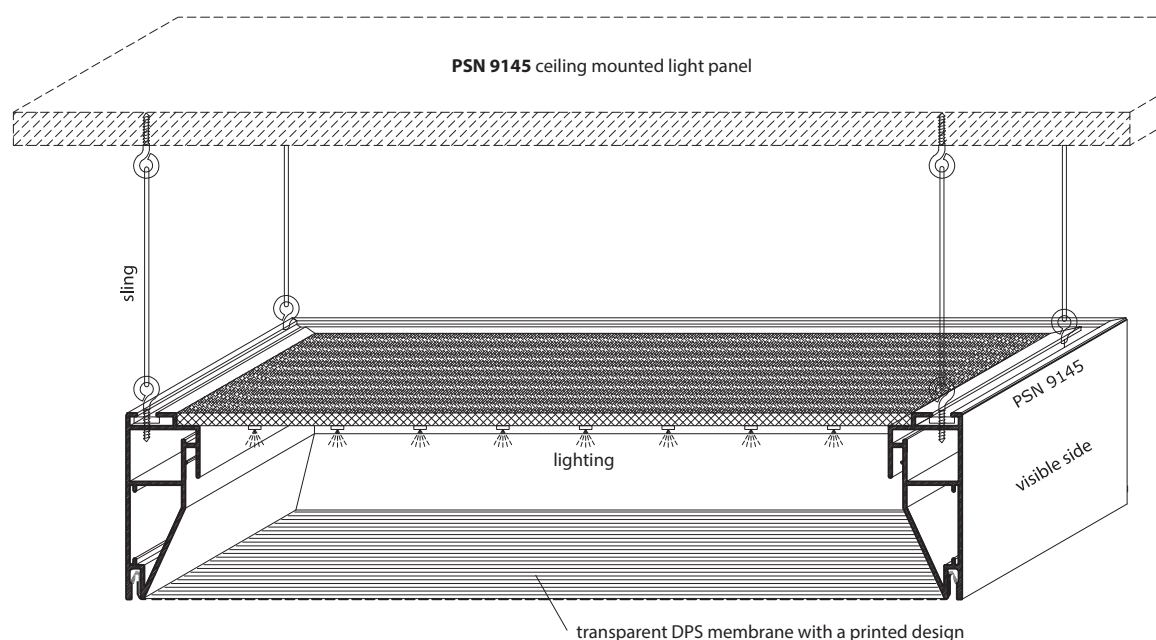

FIG. 1 | LIGHTING OR ADVERTISING PANEL



model:	PSN 9145
product code:	91.45
material:	aluminium 6060 T6
trading length:	5.0 lm
weight:	1.92 kg/lm
assembly holes:	none
notches:	none
bending:	no
compatibility:	alu harpoon, W2W

FIG 2. | ACOUSTIC PANEL

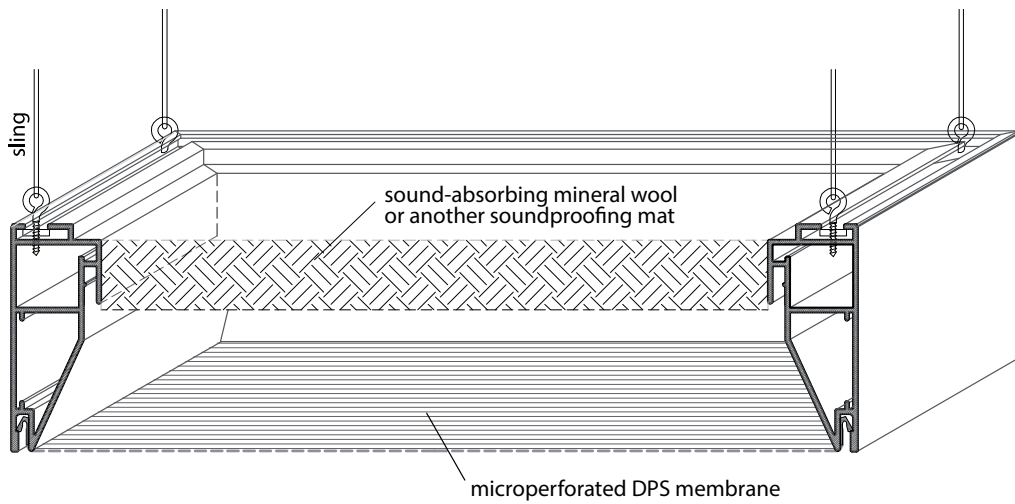

FIG 3. | SEPARATE PANEL - CEILING OR WALL ASSEMBLY

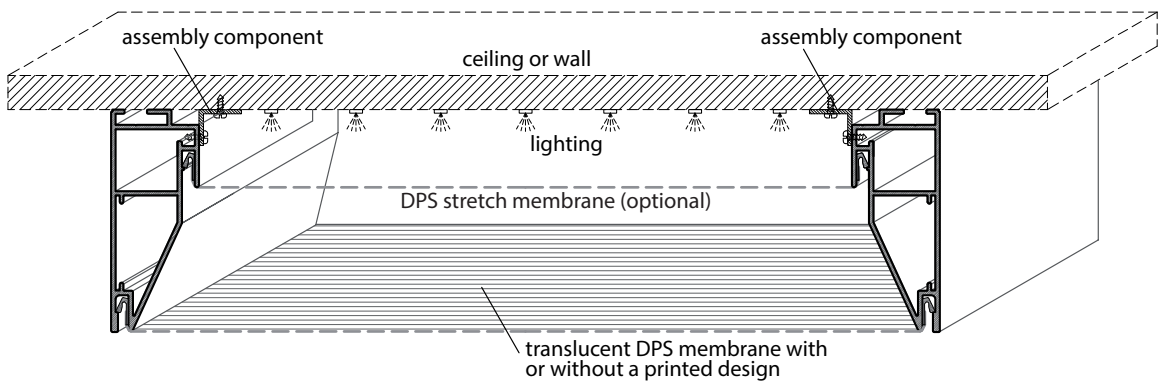

FIG. 4 | INTEGRATED PANELS

Separate panel on the ceiling

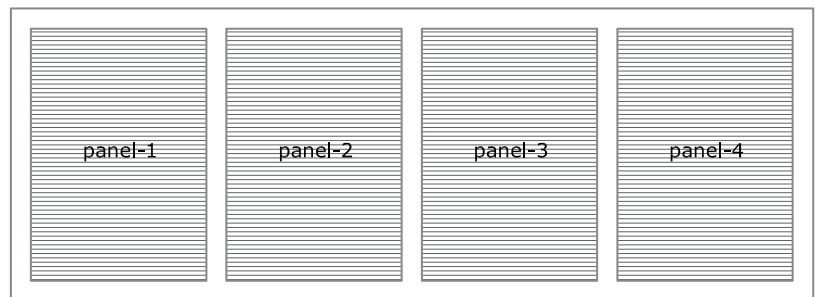
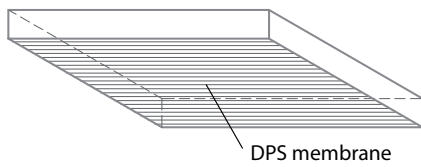
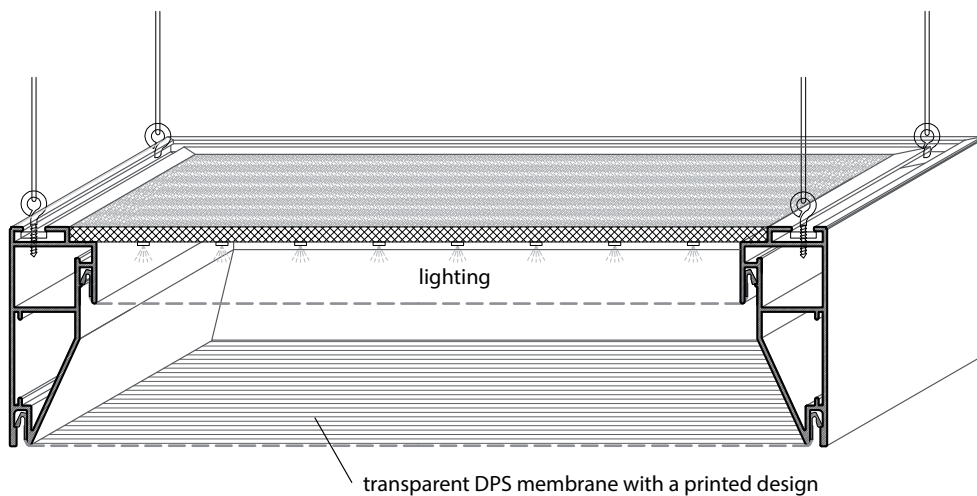

FIG.5 | ADVERTISING OR DECORATIVE PANEL



ALX1

BENDING PROFILE

A bending profile used for stretch ceiling sheets in the STANDARD system.

The profile makes it possible to create multi-level or three-dimensional elements.

Upon request, the profile may be powder coated or anodized.

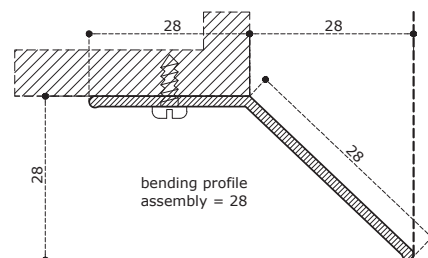

bending profile assembly in STANDARD system

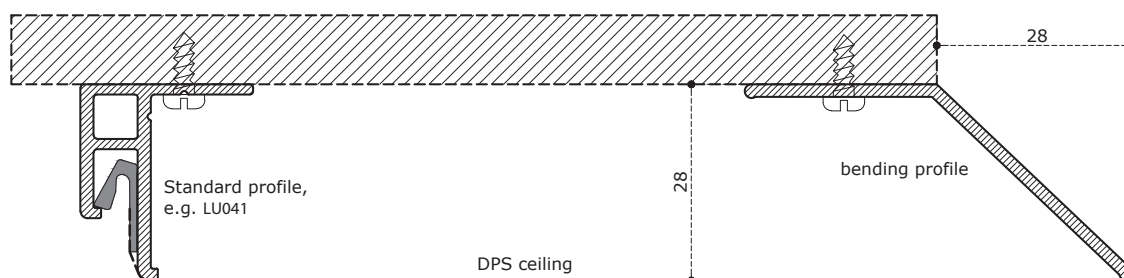

model:	ALX 1 BENDING PROFILE [aluminium 6060 T6]
product code:	ALX1
trading length:	2.5 lm
weight:	0.324 kg/lm
assembly holes:	none
notches:	none
assembly:	wall / ceiling / support structure
compatibility:	STANDARD collection

DIVISION OF ONE SHEET INTO TWO PLAINS WITH BENDING PROFILE

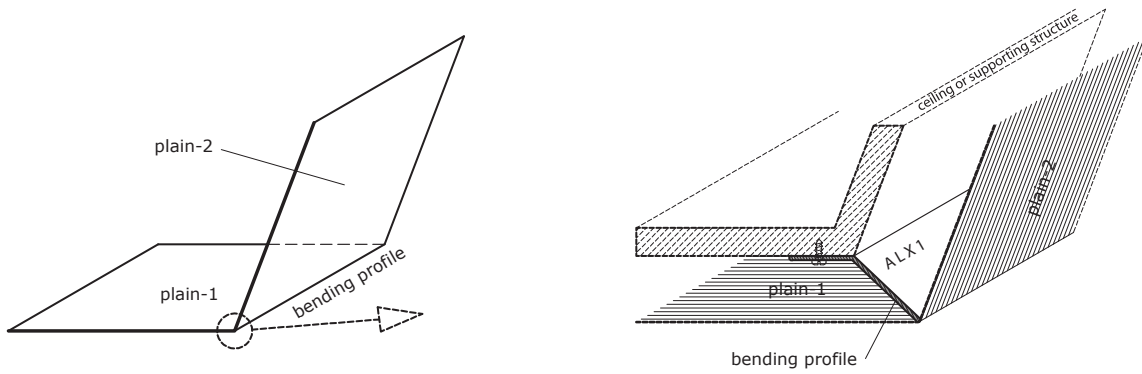

COVER FOR CEILING JOIST, AIR DUCT, TUBES ETC.

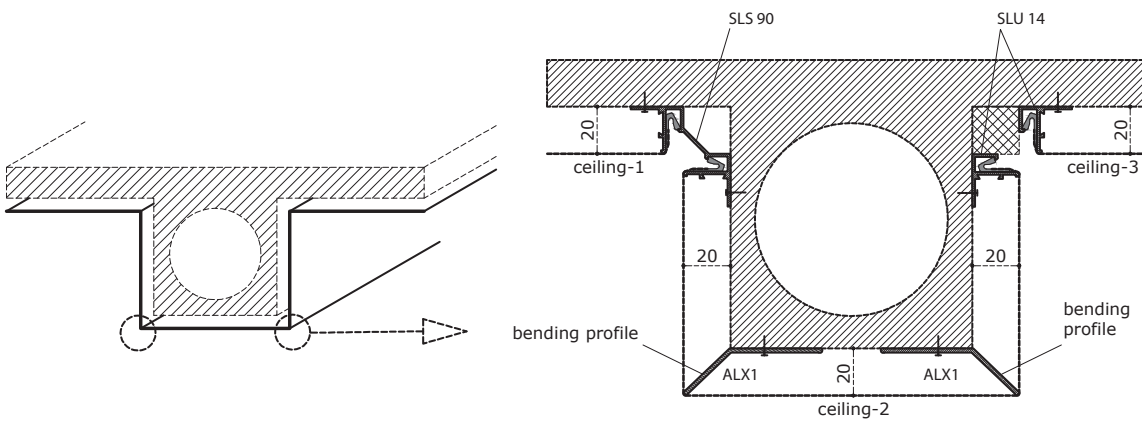

DECORATIVE COVER FOR PILLAR, COLUMN, ETC.

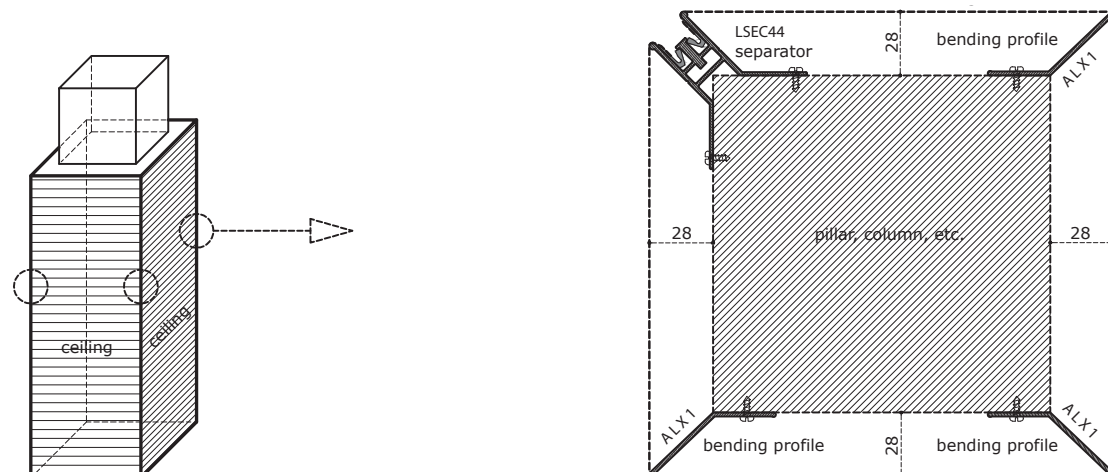

LU-KL

This special profile is attached to surfaces like ceramics, glass and metal by means of assembly glue without the necessity to use bolts or screws.

The glue is applied to side „A” of a profile cut to appropriate length and pressed against the target surface. In order to attach it to vertical surfaces, it needs to be secured from sliding below the required level, for instance by means of adhesive tape blocks.

Using the glue additionally seals the space above the stretch ceiling.

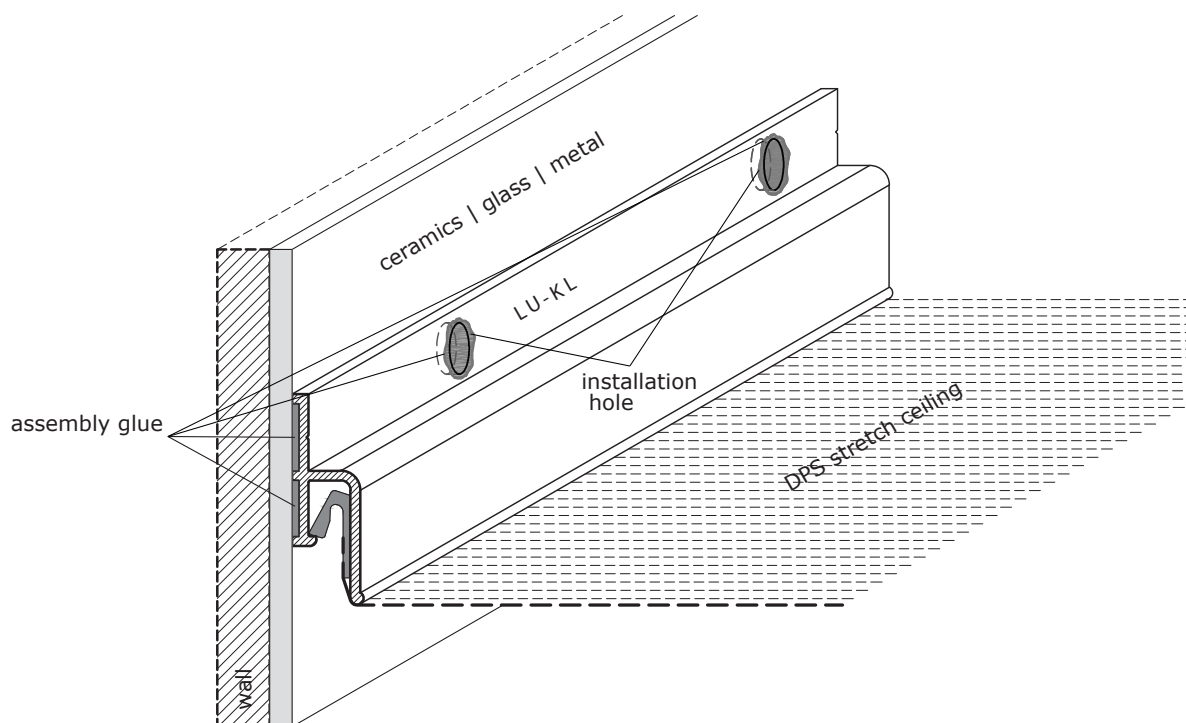
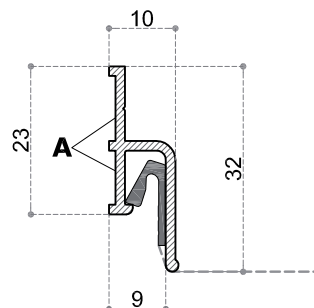











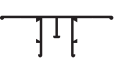

model:	LU-KL [aluminium 6060 T6]	
product code:	S04X000	S04W000
trading length:	2.5 lm	2.5 lm
weight:	0.217 kg/lm	0.208 kg/lm
assembly holes:	none	Ø 6 every 30 cm
notches:	none	none
assembly:	wall (W)	
compatibility:	alu white harpoon, alu black harpoon	

PROFILE LIST

The SLIM profile system is intended for ceilings whose size does not exceed 30 m².

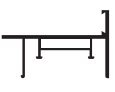
The DPS Group shall not be held liable for misuse of SLIM collection profiles.

PAGE	CROSS-SECTION	MODEL	CODE	DRILL IN		WAVE NOTCHES		CIRCLE NOTCHES	
				CEILING	WALL	2 cm	4 cm	2 cm	4 cm
36		SLU 11	A11X000	X	A11W000	X	X	A11WK20	A11WK40
37		SLU 14	A14X000	A14C000	X	X	X	A14CK20	A14CK40
38		SLS 140	A140X000	A140C000	X	A140CF20	A140CF40	X	X
39		SLS 150	A150X000	A150C000	X	A150CF20	A150CF20	X	X
40		SLS 90	A90X000	X	X	X	X	X	X
41		SLS 270	A270X000	X	X	X	X	X	X
42		A 60	A60X000	A60C000	A60W000	X	X	X	X
44		SLS 240	A240X000	X	A240W000	A240WF20	A240WF40	X	X
46		SLM 01	AM01X000	X	AM01W000	AM01WF20	X	AM01WK20	X
48		DL75	A75X000	X	A75W000	X	X	A75WK20	A75WK40
50		A 50	A50X000	A50C000	A50W000	X	X	X	X
51		A 100	A100X000	A100C000	A100W000	X	X	X	X
53		ALX1	ALX1	X	X	X	X	X	X
54		PSP II	PSP II	X	X	X	X	X	X

SLU 11

The counterpart of the **STANDARD** collection LU 01 profile.

May be applied as a substitute profile with a smaller assembly slot.

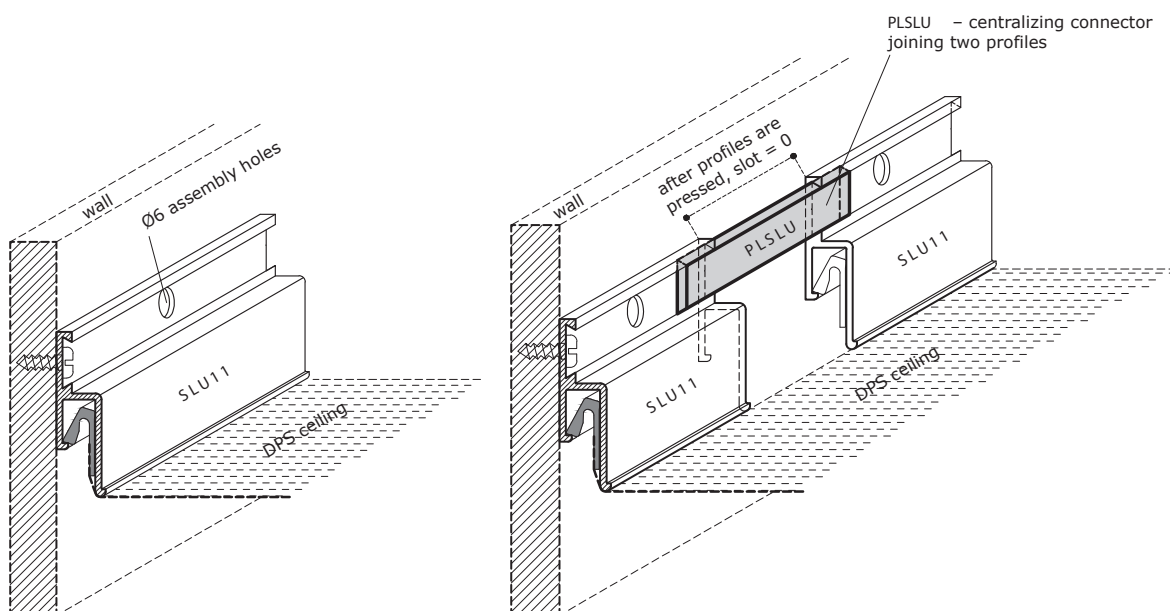
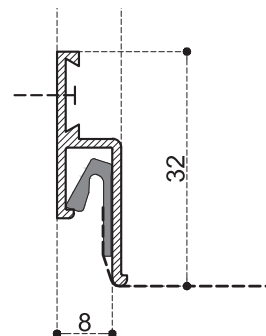

model:	SLU 11 [aluminium 6060 T6]			
product code:	A11X000	A11W000	A11WK20*	A11WK40*
trading length:	2.5 lm	2.5 lm	2.5 lm	2.5 lm
weight:	0.180 kg/lm	0.174 kg/lm	0.158 kg/lm	0.166 kg/lm
assembly holes:	none	Ø 6 every 20 cm	Ø 6 every 20 cm	Ø 6 co 20 cm
notches:	none	none	every 2 cm/circle	every 4 cm/circle
assembly:	wall (w)			
compatibility:	alu white harpoon, alu black harpoon			
comments:	using the SLIM PROTECTOR element			

SLU 14

The counterpart of the **STANDARD** collection LU 041 profile.

May be applied as a substitute profile with a smaller assembly slot.

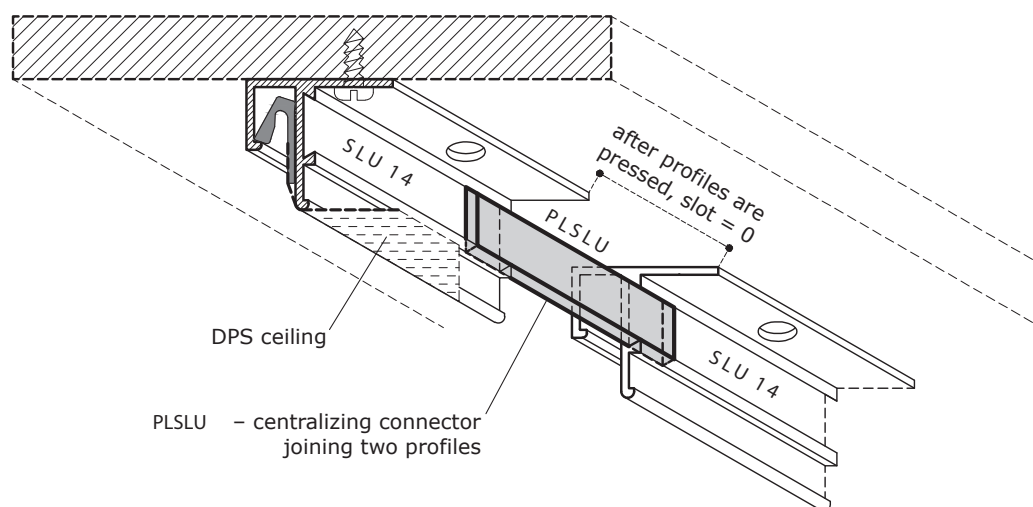
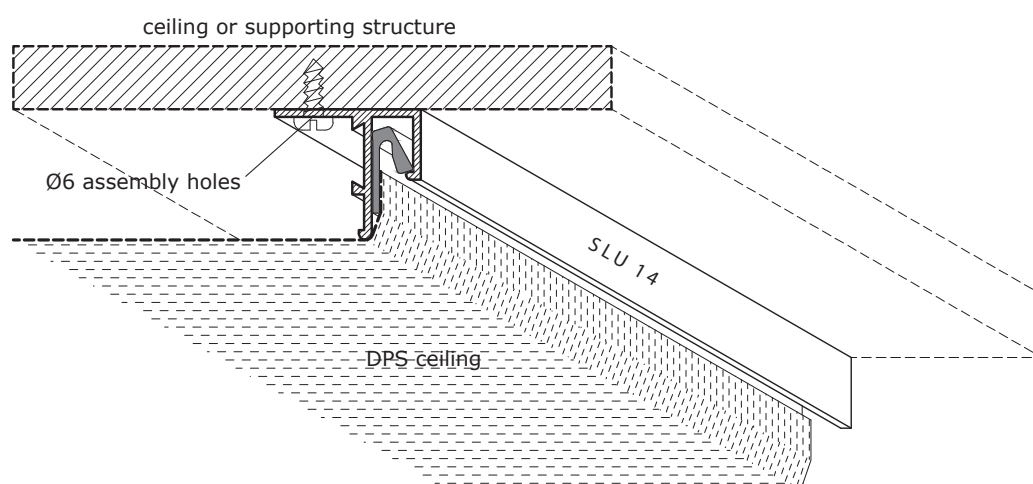
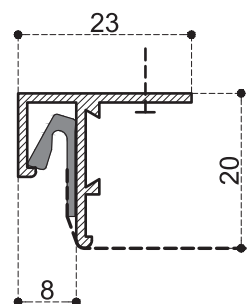

model:	SLU 14 [aluminium 6060 T6]			
product code:	A14X000	A14C000	A14CK20*	A14CK40*
trading length:	2.5 lm	2.5 lm	2.5 lm	2.5 lm
weight:	0.187 kg/lm	0.181 kg/lm	0.165 kg/lm	0.173 kg/lm
assembly holes:	none	Ø 6 every 20 cm	Ø 6 every 20 cm	Ø 6 every 20 cm
notches:	none	none	every 2 cm/circle	every 4 cm/circle
assembly:	ceiling (C)			
compatibility:	alu white harpoon, alu black harpoon			
comments:	using the SLIM PROTECTOR element			

SLS 140

A separating profile that differs from the SLS 150 profile in assembly slot width.

Used for low-hanging ceilings to add aesthetic value to ceiling separations.

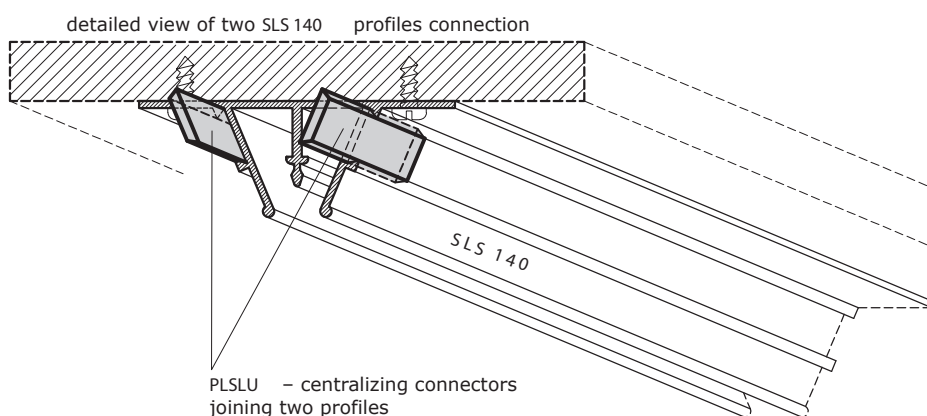
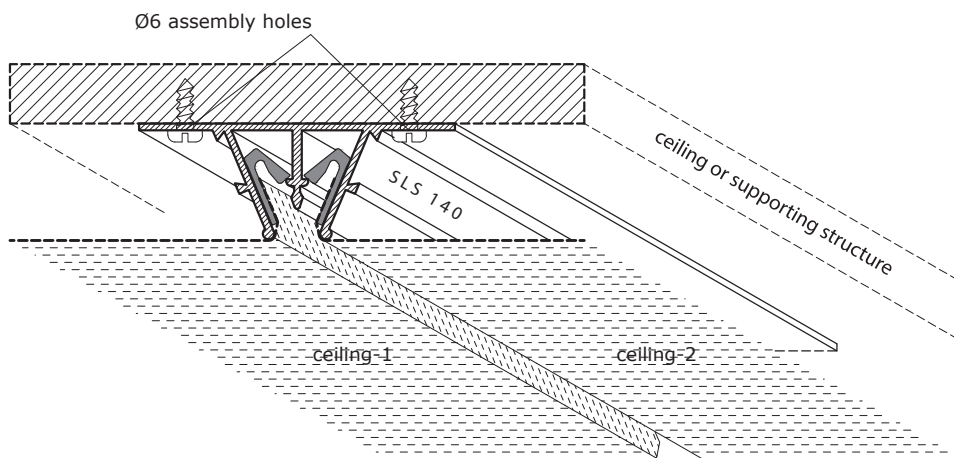
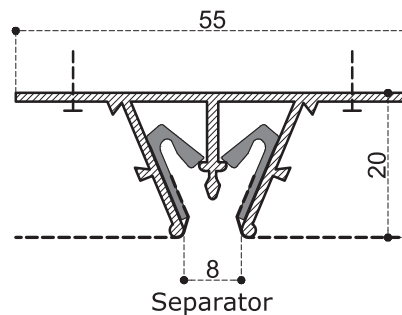

model:	SLS 140 [aluminium 6060 T6]			
product code:	A140X000	A140C000	A140CF20*	A140CF40*
trading length:	2.5 lm	2.5 lm	2.5 lm	2.5 lm
weight:	0.405 kg/lm	0.395 kg/lm	0.355 kg/lm	0.375 kg/lm
assembly holes:	none	Ø 6 every 20 cm	Ø 6 every 20 cm	Ø 6 every 20 cm
notches:	none	none	every 2 cm/wave	every 4 cm/wave
assembly:	ceiling (C)			
compatibility:	alu white harpoon, alu black harpoon			

SLS 150

The counterpart of the STANDARD collection LS044 profile. May be applied as a substitute profile with a smaller assembly slot.

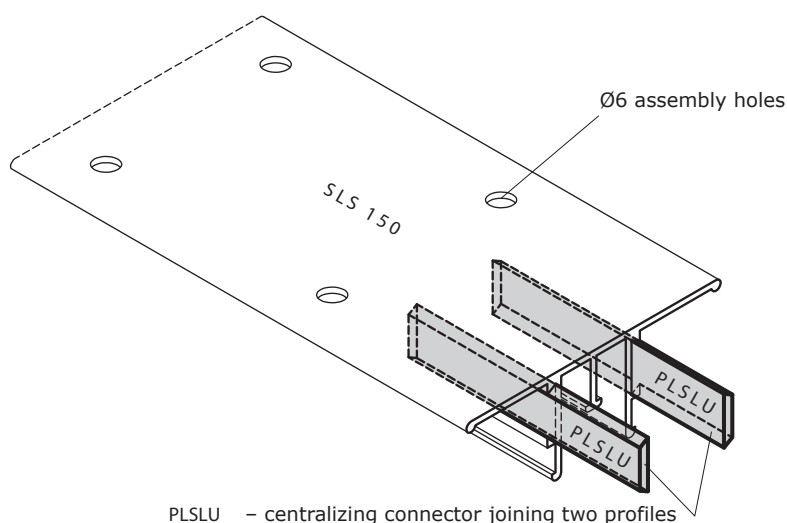
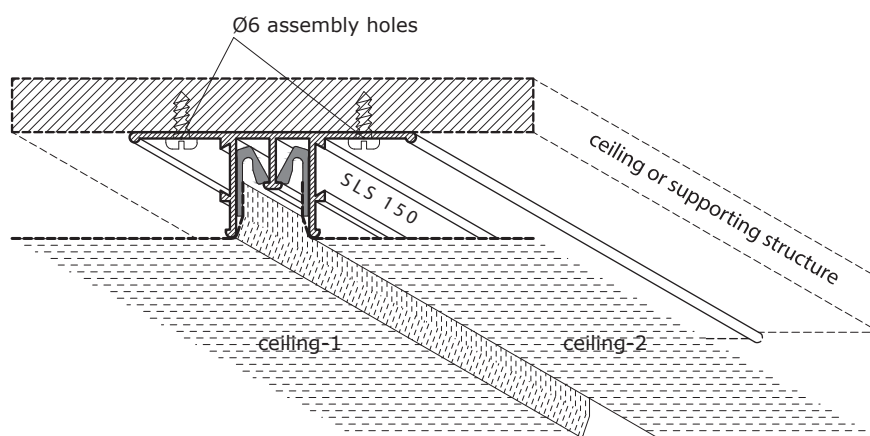
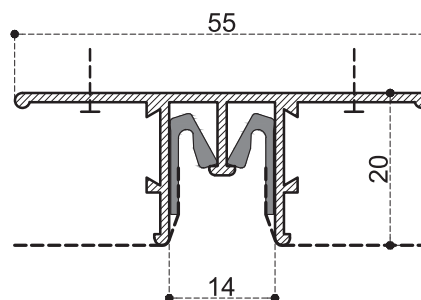

PLSLU – centralizing connector joining two profiles

model:	SLS 150 [aluminium 6060 T6]			
product code:	A150X000	A150C000	A150CF20*	A150CF40*
trading length:	2.5 lm	2.5 lm	2.5 lm	2.5 lm
weight:	0.380 kg/lm	0.374 kg/lm	0.342 kg/lm	0.358 kg/lm
assembly holes:	none	Ø 6 every 20 cm	Ø 6 every 20 cm	Ø 6 every 20 cm
notches:	none	none	every 2 cm/wave	every 4 cm/wave
assembly:	ceiling (C)			
compatibility:	alu white harpoon, alu black harpoon			

SLS 90

The counterpart of the **STANDARD** collection **LSIC 44** profile. May be applied as a substitute profile with a smaller assembly slot.

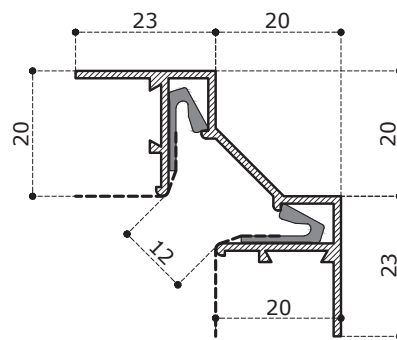

internal corner separator

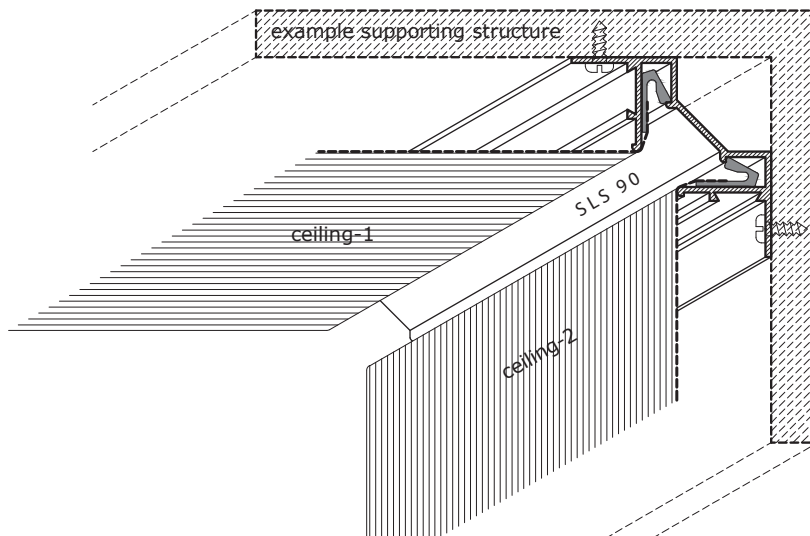

detailed view of two profiles connection

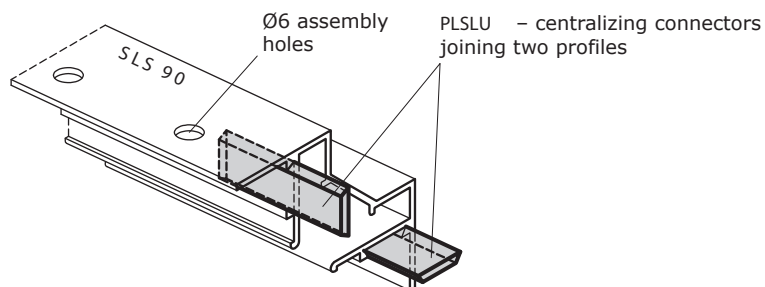

model:	SLS 90 [aluminium 6060 T6]
product code:	A90X000
trading length:	2.5 lm
weight:	0.420 kg/lm
assembly holes:	none
notches:	none
assembly:	wall (W) + ceiling (C) / support structure
compatibility:	alu white harpoon, alu black harpoon

SLS 270

The counterpart of the **STANDARD** collection **LSEC 44** profile. May be applied as a substitute profile with a smaller assembly slot.

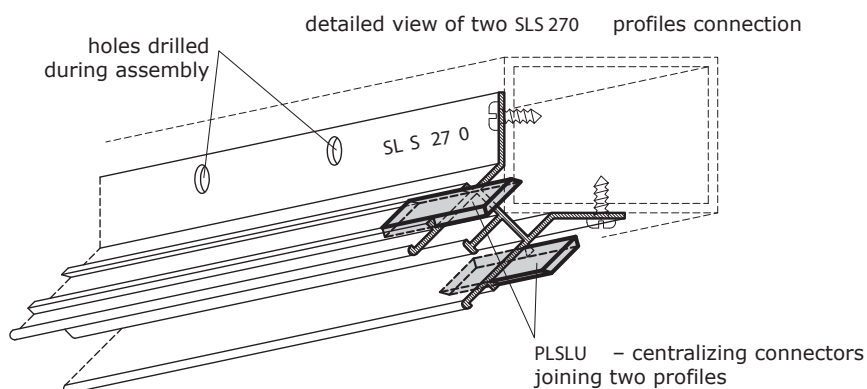
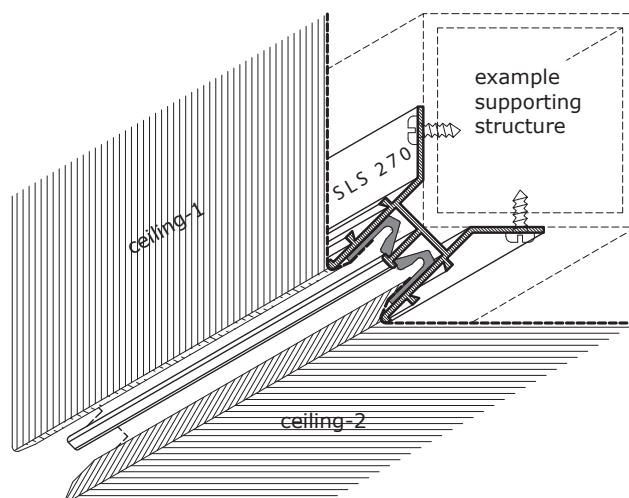
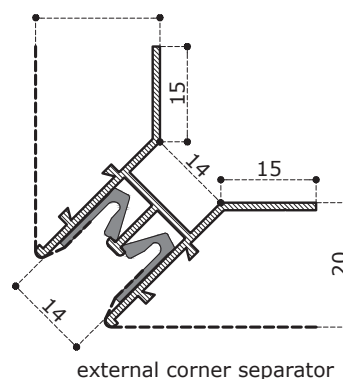

model:	SLS 270 [aluminium 6060 T6]
product code:	A270X000
trading length:	2.5 lm
weight:	0.391 kg/lm
assembly holes:	none
notches:	none
assembly:	wall (W) + ceiling (C) / support structure
compatibility:	alu white harpoon, alu black harpoon

A 60 W2W-SLIM

The A60 W2W-SLIM is a special separating profile attached to a supporting structure.

It enables the connection of SLIM collection ceilings with Wall2Wall ceilings.

Upon request, the profile may be powder-coated or anodized.

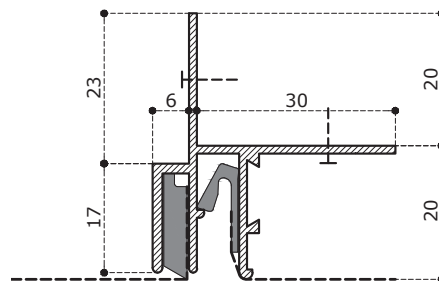

double-system separating profile

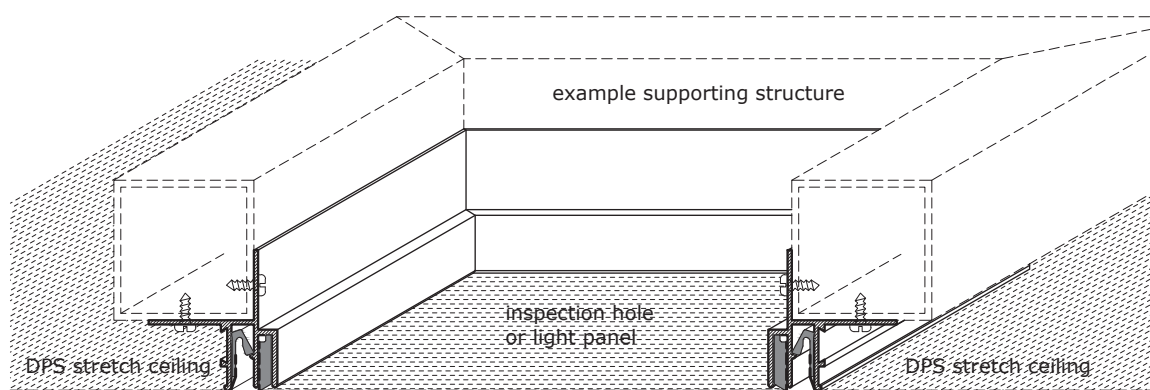

SLIM system,
ALU harpoon

slotless system,
W2W harpoon

SLIM system,
ALU harpoon

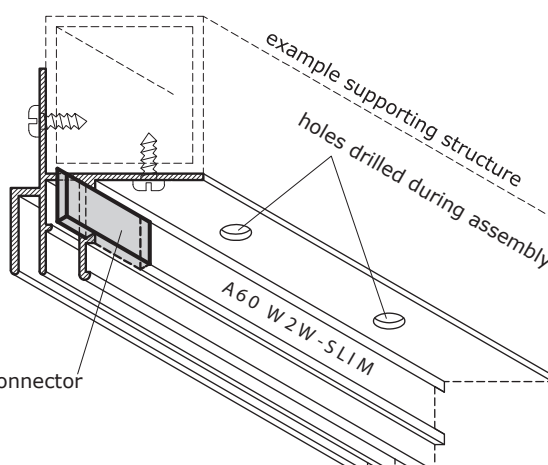

PLSLU – centralizing connector
joining two profiles

model:	A 60 W2W-SLIM [aluminium 6060 T6]		
product code:	A60X000	A60C000	A60W000
trading length:	2.5 lm	2.5 lm	2.5 lm
weight:	0.388 kg/lm	0.376 kg/lm	0.376 kg/lm
assembly holes:	none	Ø 6 every 20 cm	Ø 6 every 20 cm
notches:	none	none	none
assembly:	ceiling (C) / wall (W)		
compatibility:	alu white harpoon, alu black harpoon		

INSPECTION HOLE IN DPS STRETCH CEILING

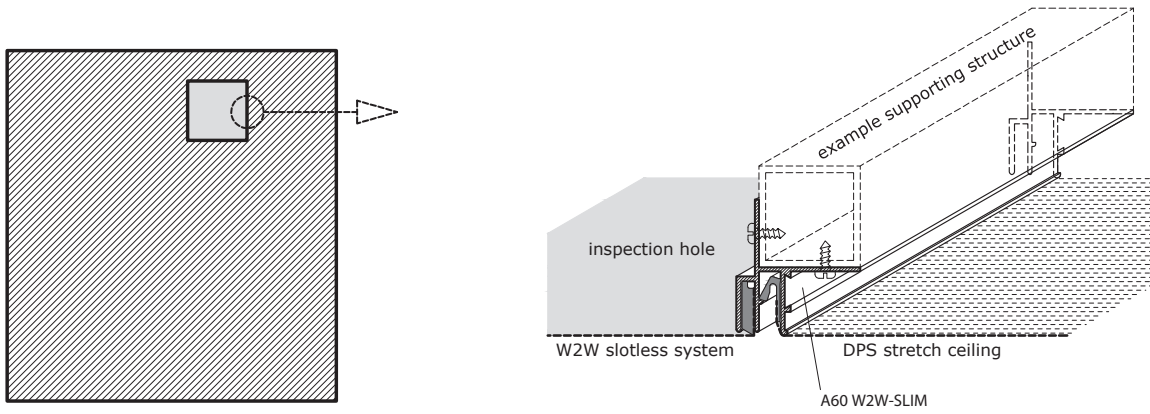

STRIPS ON DPS STRETCH CEILING

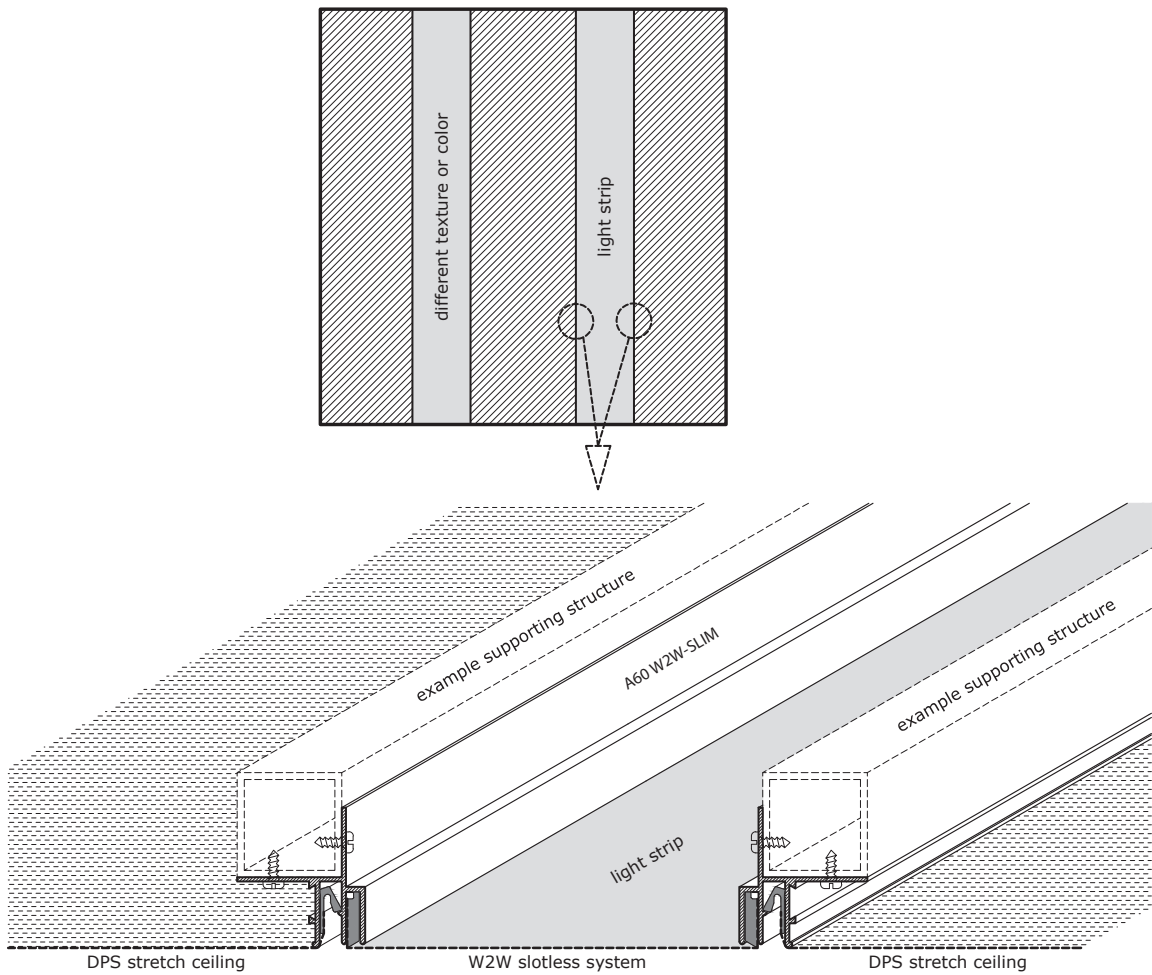

SLS 240

A separating profile used to join stretch ceiling sheets. Made specifically for narrow supporting structures.

When wave-notched, the profile can easily be molded to fit a curved ceiling.

Large curve radius - notch every 4 cm

Small curve radius - notch every 2 cm

Reducing the gap between connected sheets helps improve the visual effect of the ceiling.

This profile may be powder coated or anodized upon request.

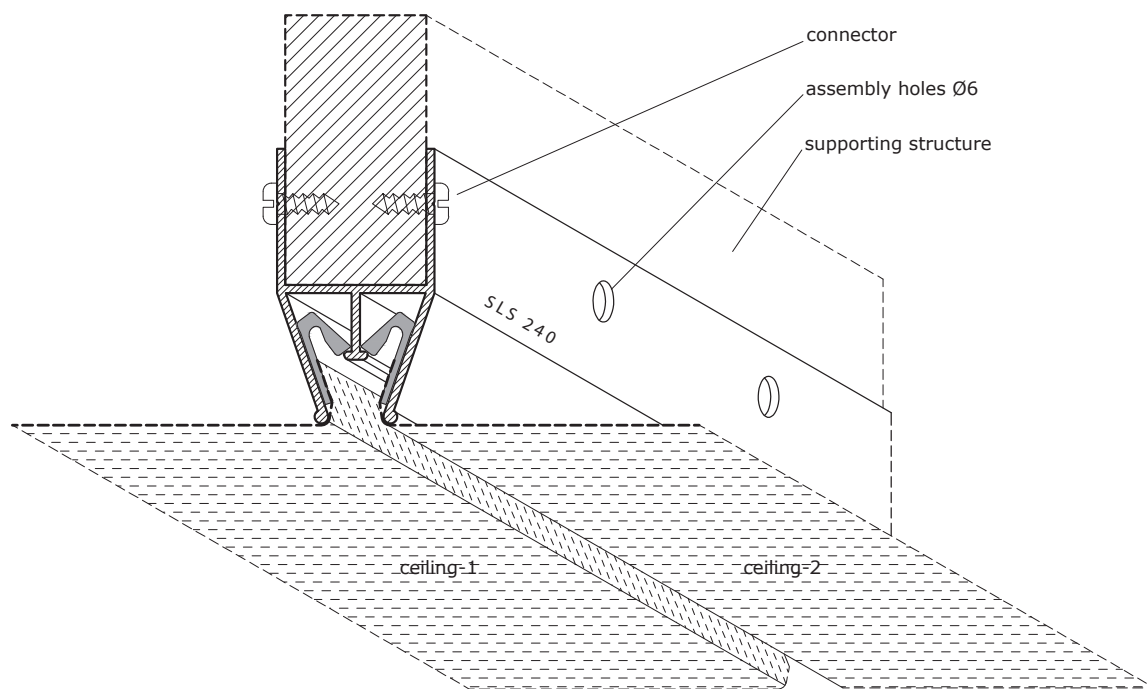
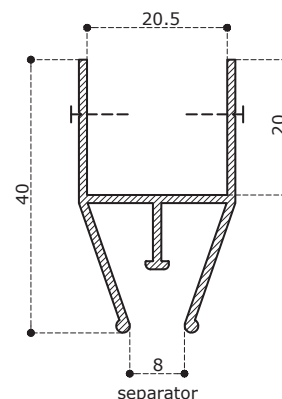

model:	SLS 240 [aluminium 6060 T6]			
product code:	A240X000	A240W000	A240WF20	A240WF40
trading length:	2.5 lm	2.5 lm	2.5 lm	2.5 lm
weight:	0.376 kg/lm	0.368 kg/lm	0.362 kg/lm	0.364 kg/lm
assembly holes:	none	Ø 6 every 20 cm	Ø 6 every 20 cm	Ø 6 every 20 cm
notches:	none	none	every 2 cm/wave	every 4 cm/wave
assembly:	wall (W)			
compatibility:	alu white harpoon, alu black harpoon			

CURVED CEILING

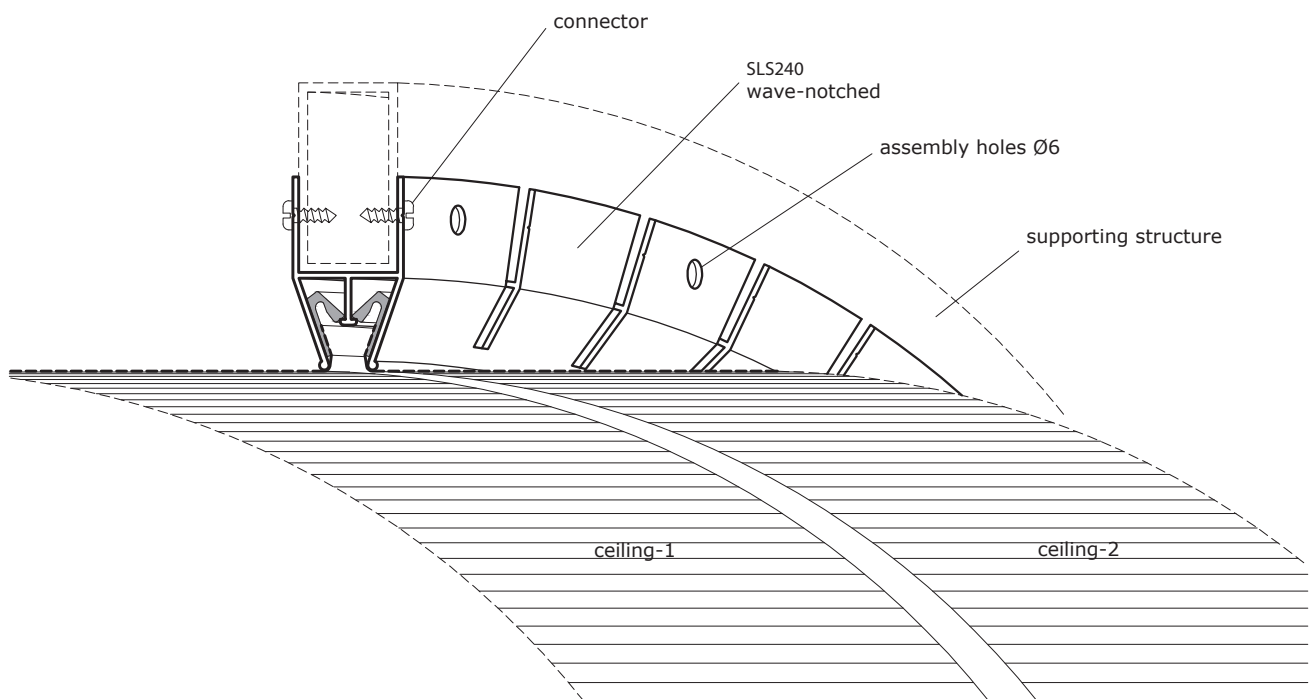
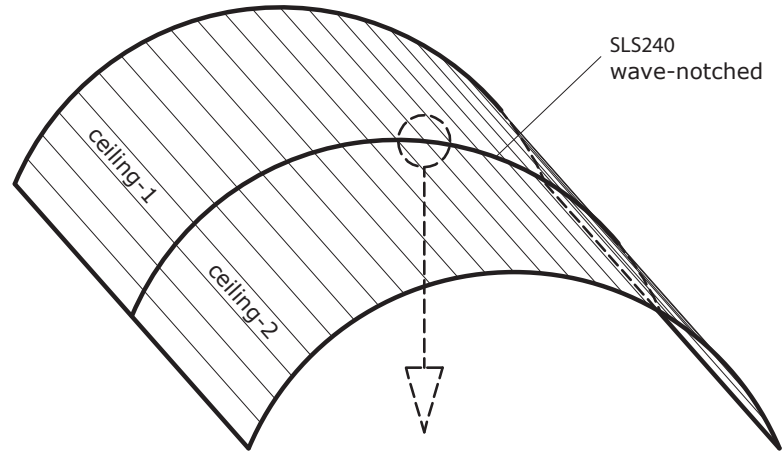

SLM 01

The basic profile for the DPS MOSAIC and MO-SAIC light systems.

The profile allows the installation of two separate stretch ceilings: decorative and translucent.

It can be notched to create irregular shapes such as circles or ellipses.

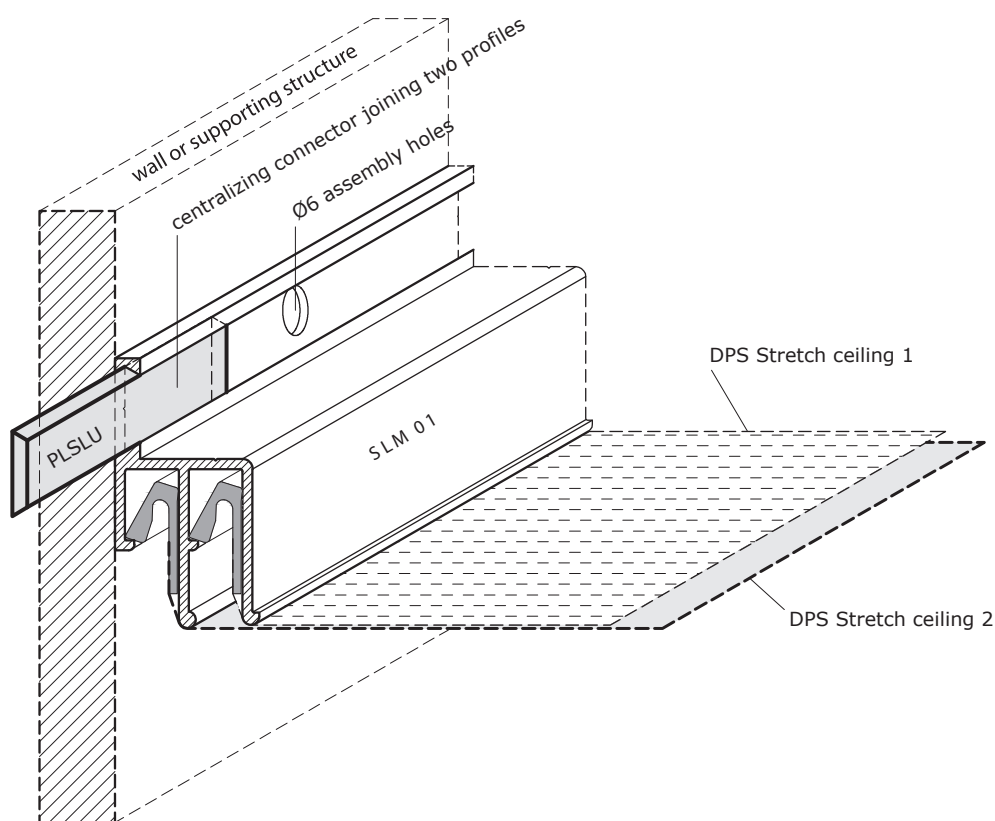
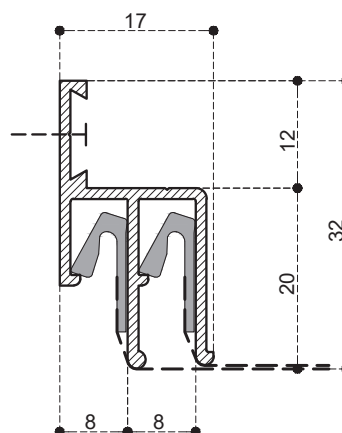

model:	SLM 01 [aluminium 6060 T6]			
product code:	AM01X000	AM01W000	AM01WK20*	AM01WF40*
trading length:	2.5 lm	2.5 lm	2.5 lm	2.5 lm
weight:	0.271 kg/lm	0.263 kg/lm	0.248 kg/lm	0.246 kg/lm
assembly holes:	none	Ø 6 every 20 cm	Ø 6 every 20 cm	Ø 6 every 20 cm
notches:	none	none	every 2 cm/circle	every 4 cm/circle
assembly:	wall (W)			
compatibility:	alu white harpoon, alu black harpoon			
comments:	*using the SLIM PROTECTOR element			

DPS MOSAIC

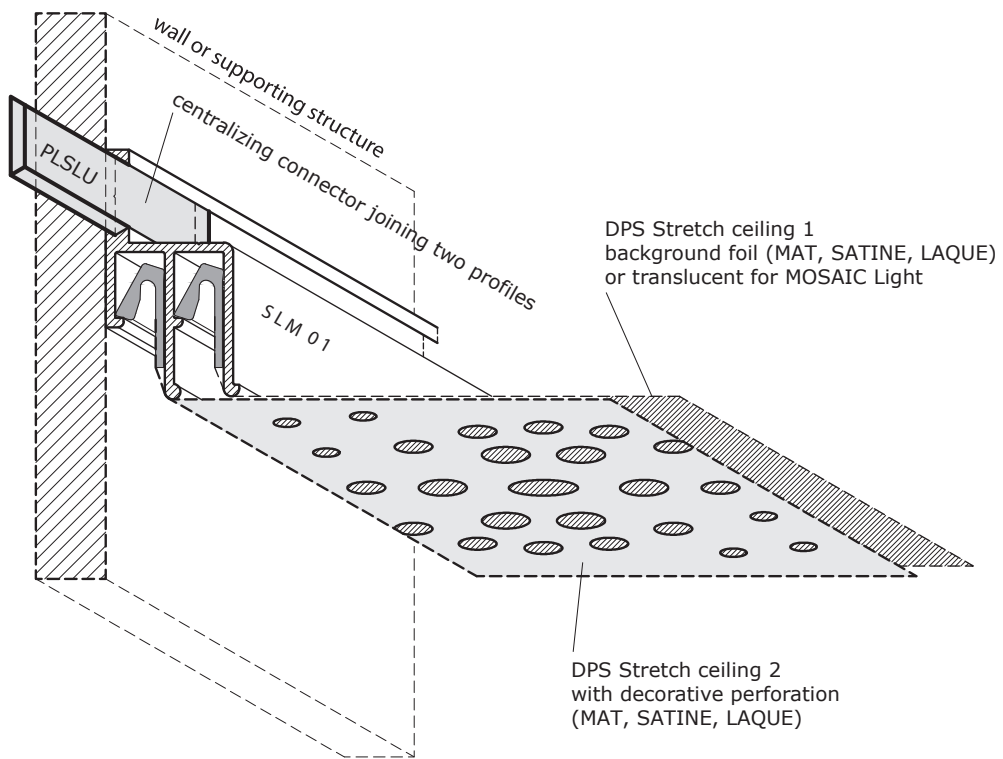

DPS MOSAIC LIGHT - LUMINOUS VERSION WITH PATTERN ON CEILING NO. 1

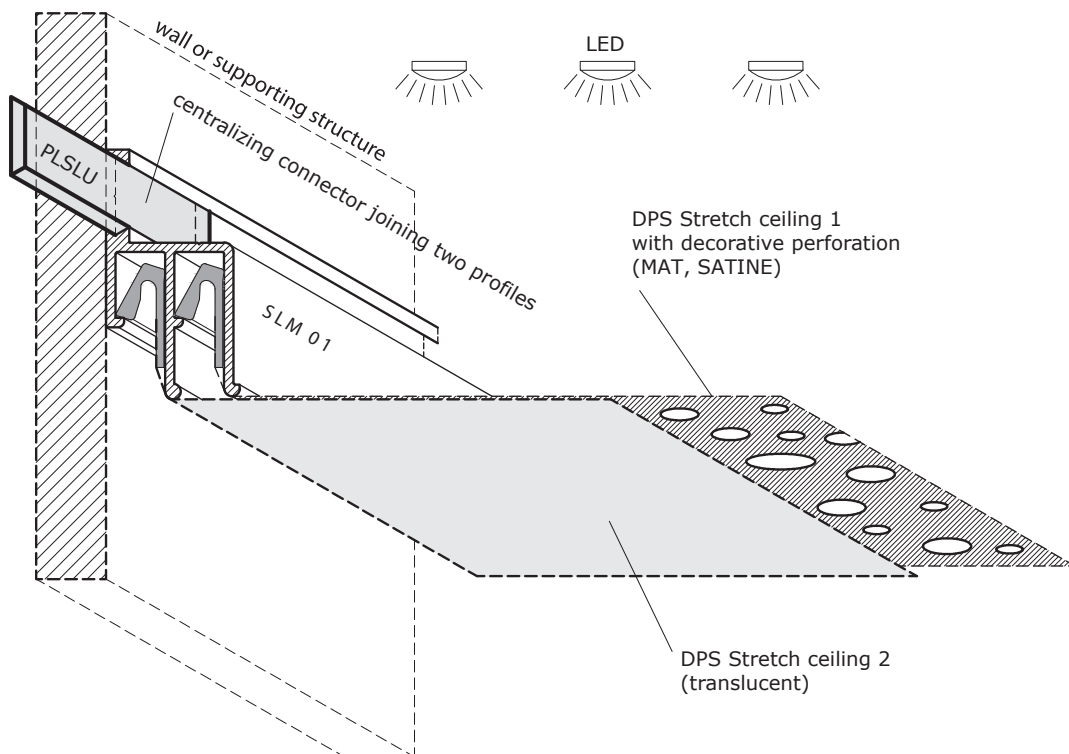

DL 75

The DL 75 SLIM profile allows you to make multi-level ceilings with the use of stretch membranes. It facilitates the creation of 3D light elements of any shape.

Thanks to its structure, it makes it possible to evenly distribute LED lighting and create shadow-free lighting elements.

Upon request, the profile may be powder coated or anodized.

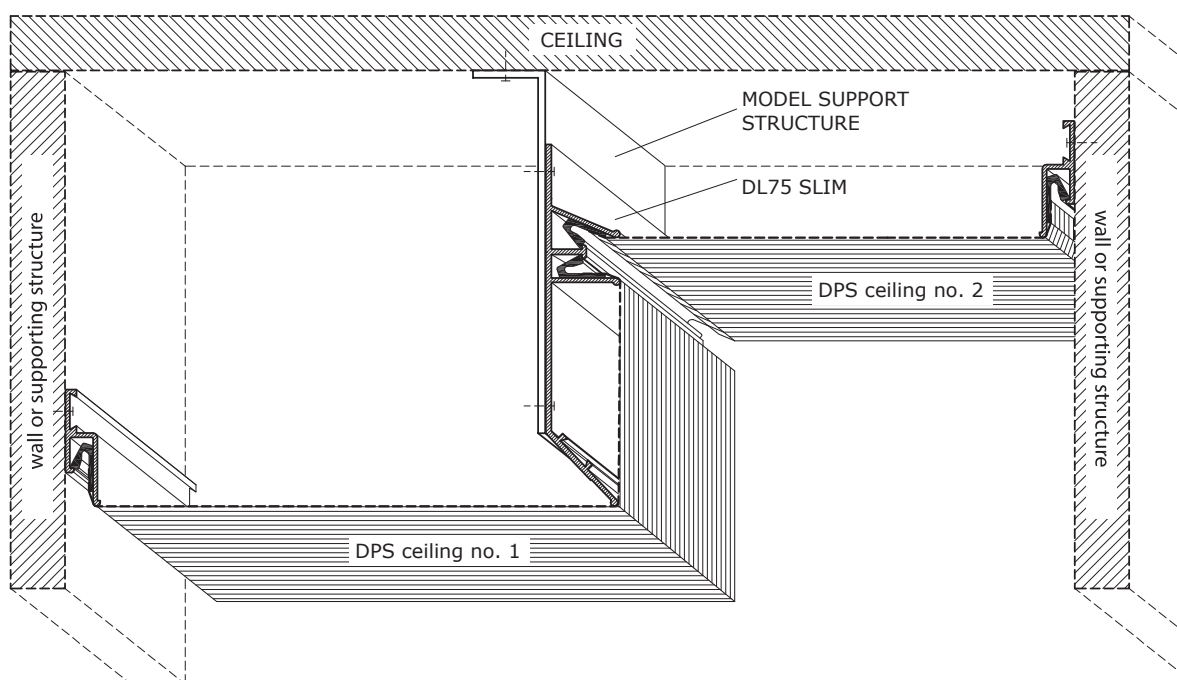
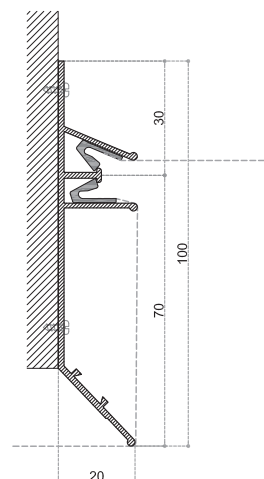

model:	DL 75 SLIM [aluminium 6060 T6]			
product code:	A75X000	A75W000	A75WK20*	A75WK40*
trading length:	2.5 lm	2.5 lm	2.5 lm	2.5 lm
weight:	0.634 kg/lm	0.627 kg/lm	0.634 kg/lm	0.562 kg/lm
assembly holes:	none	Ø 6 every 20 cm	none	none
notches:	none	none	every 2 cm/circle	every 4 cm/circle
assembly:	wall (W)			
compatibility:	alu white harpoon, alu black harpoon			
comments:	* minimum radius - 2,5 m / * with SLIM PROTECTOR			

CEILING WITH A SIDE OF SMALL CURVATURE

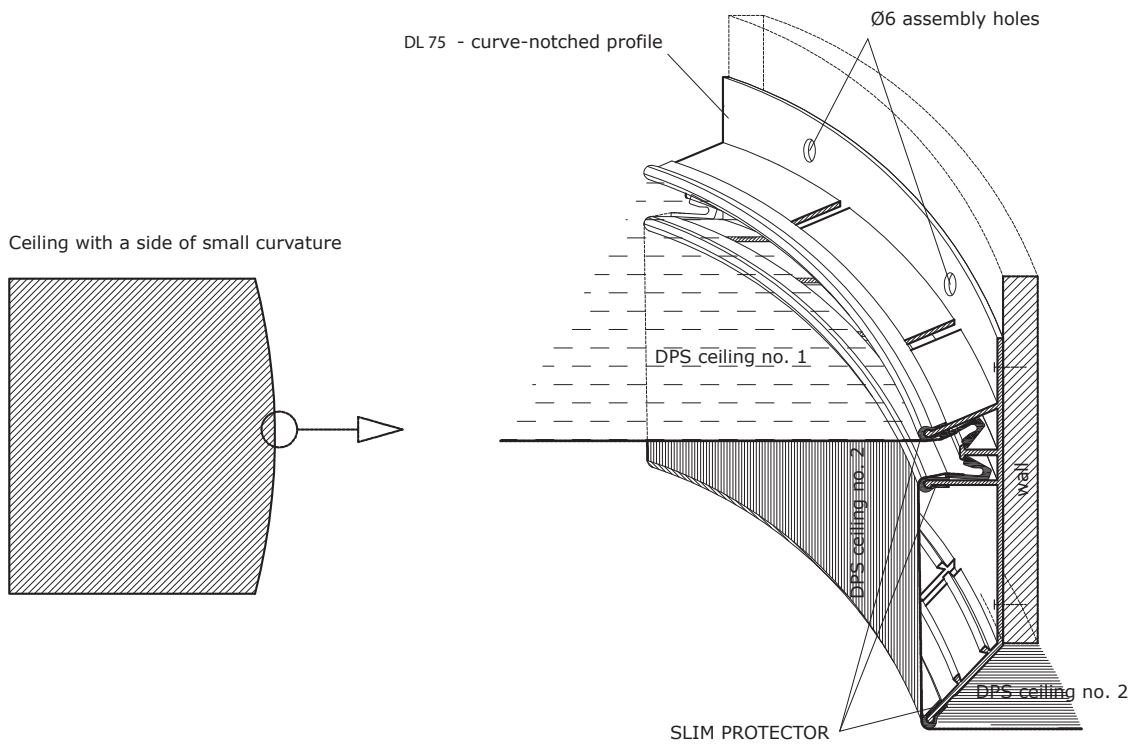

CIRCLE-SHAPED CEILINGS OF SMALLER RADIUS

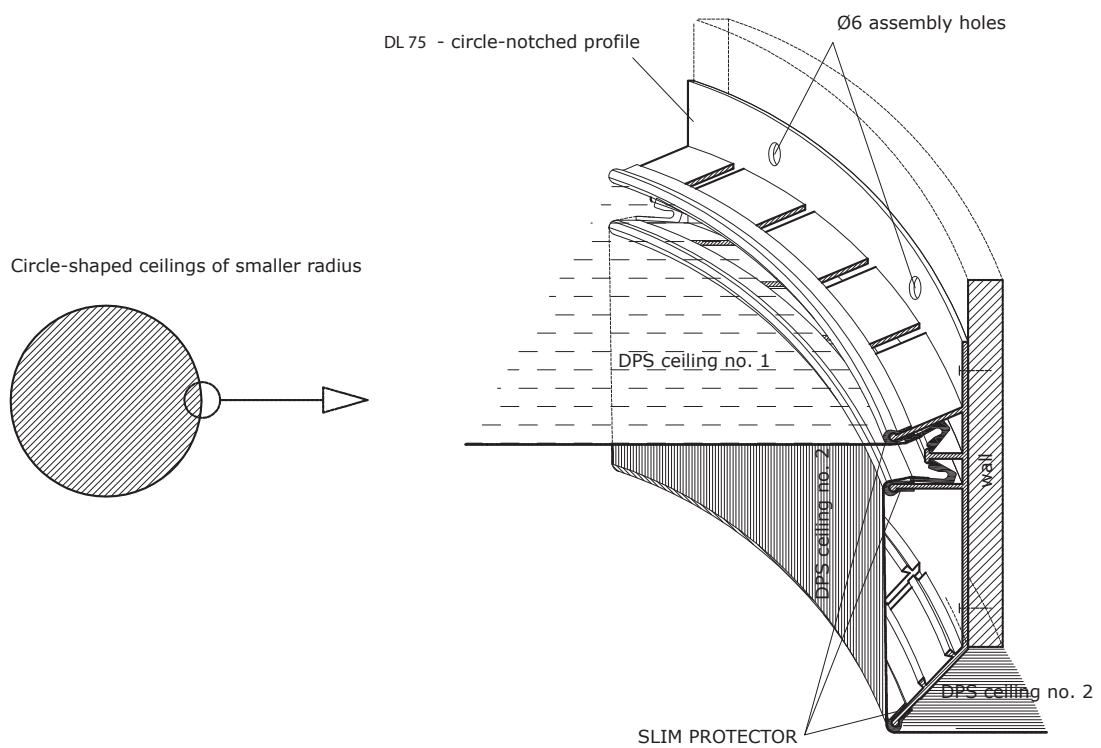

A50

LIGHTING PROFILE

The A50 is a universal profile that may be attached to the wall or serve as a sheet separator.

The light reflector effectively disperses light and makes the whole ceiling look better by hiding the assembly slot.

We can obtain two types of light effects:

1. A thin line in the middle of the back panel/ reflector: by attaching the LED tape directly to the upper part of the profile [FIG. 1]
2. An even line throughout the back panels/ reflector's full width: by attaching the LED tape to a stack-on PD 200 SL distance profile [FIG. 2]

It is recommended to use dedicated light sources [ask your commercial assistant].

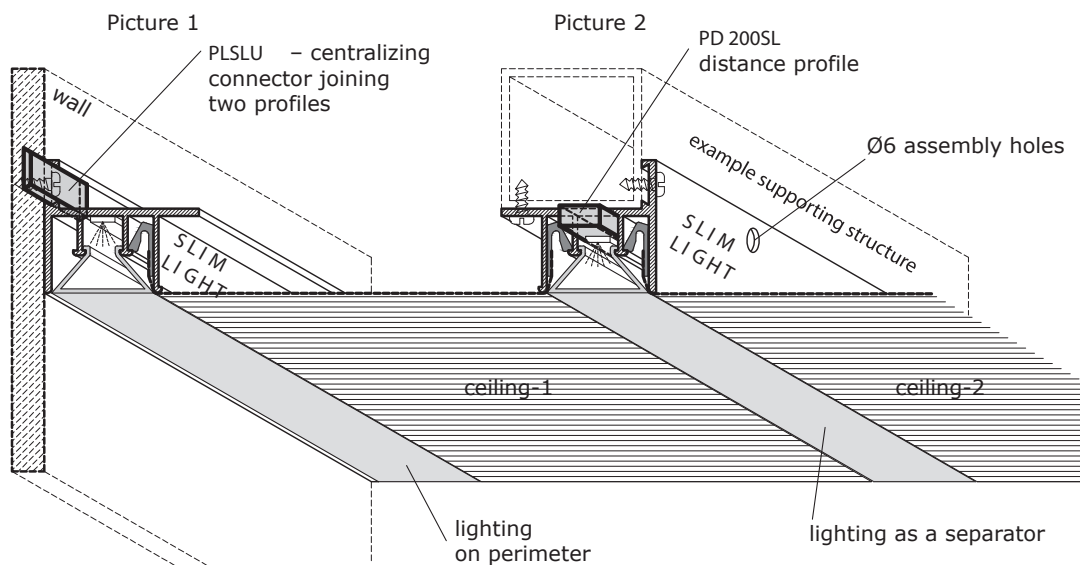
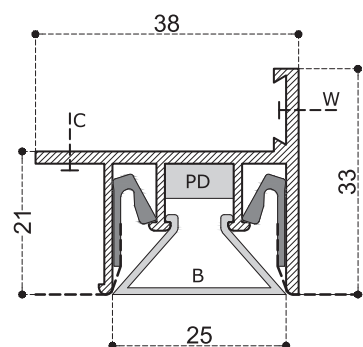

model:	A 50 slim light [aluminium 6060 T6]			BLENDE [PVC]	DISTANCE PROFILE [PVC]
product code:	A50X000	A50C000	A50W000	MP50M250	PD200SL
trading length:	2.5 lm	2.5 lm	2.5 lm	2.5 lm	2.0 lm
weight:	0.489 kg/lm	0.478 kg/lm	0.478 kg/lm	0.11 kg/lm	0.04 kg/lm
assembly holes:	none	Ø 6 every 20 cm	Ø 6 every 20 cm	clip	none
notches:	none	none	none	none	none
assembly:	wall (W) / ceiling (C)				
compatibility:	alu white harpoon, alu black harpoon				

A100

LIGHTING PROFILE

The A100 profile, similarly to the A50, may either be installed at the room perimeter or function as a separator.

The possibility to install two LED tape stripes enables the construction of utility lighting.

The set is supplemented with a back panel that covers the assembly slot and disperses light in an aesthetic manner.

The profile may be anodized upon request. It is recommended to use dedicated light sources [ask your commercial assistant].

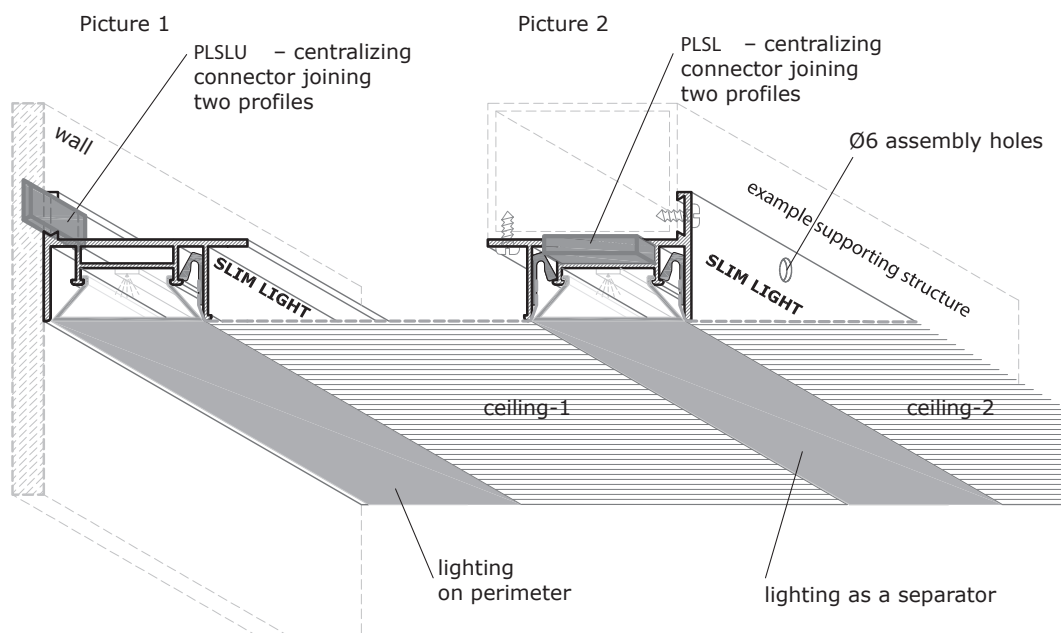
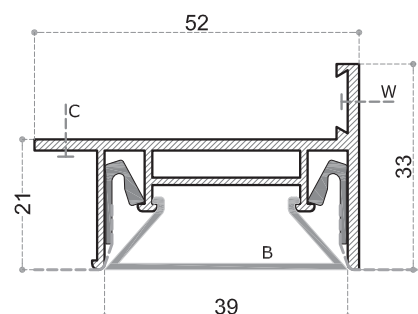

model:	A 100 slim light max [aluminium 6060 T6]			BLENDE [PVC]
product code:	A100X000	A100C000	A100W000	MP100M250
trading length:	2.5 lm	2.5 lm	2.5 lm	2.5 lm
weight:	0.605 kg/lm	0.604 kg/lm	0.603 kg/lm	0.11 kg/lm
assembly holes:	none	Ø 6 every 20 cm	Ø 6 every 20 cm	clip
notches:	none	none	none	none
assembly:	wall (W) / ceiling (C)			
compatibility:	alu white harpoon, alu black harpoon			

PERIPHERAL LIGHTING

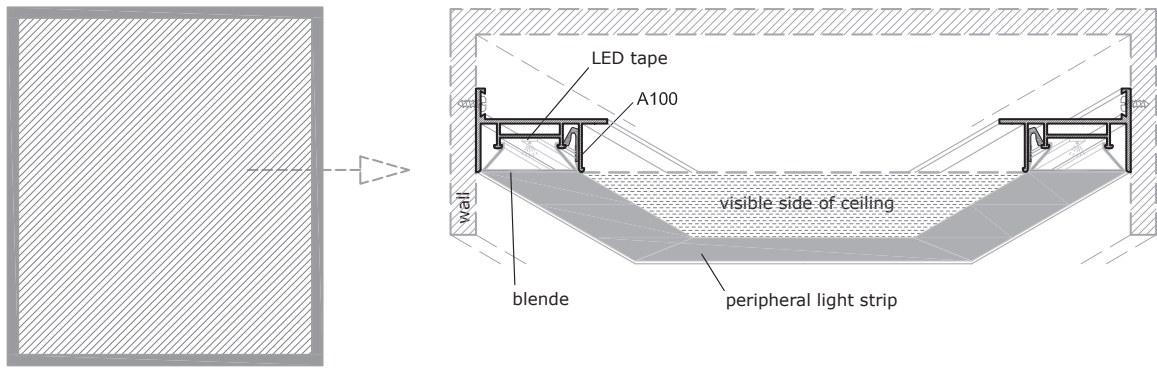

PERIPHERAL + CENTRAL LIGHTING

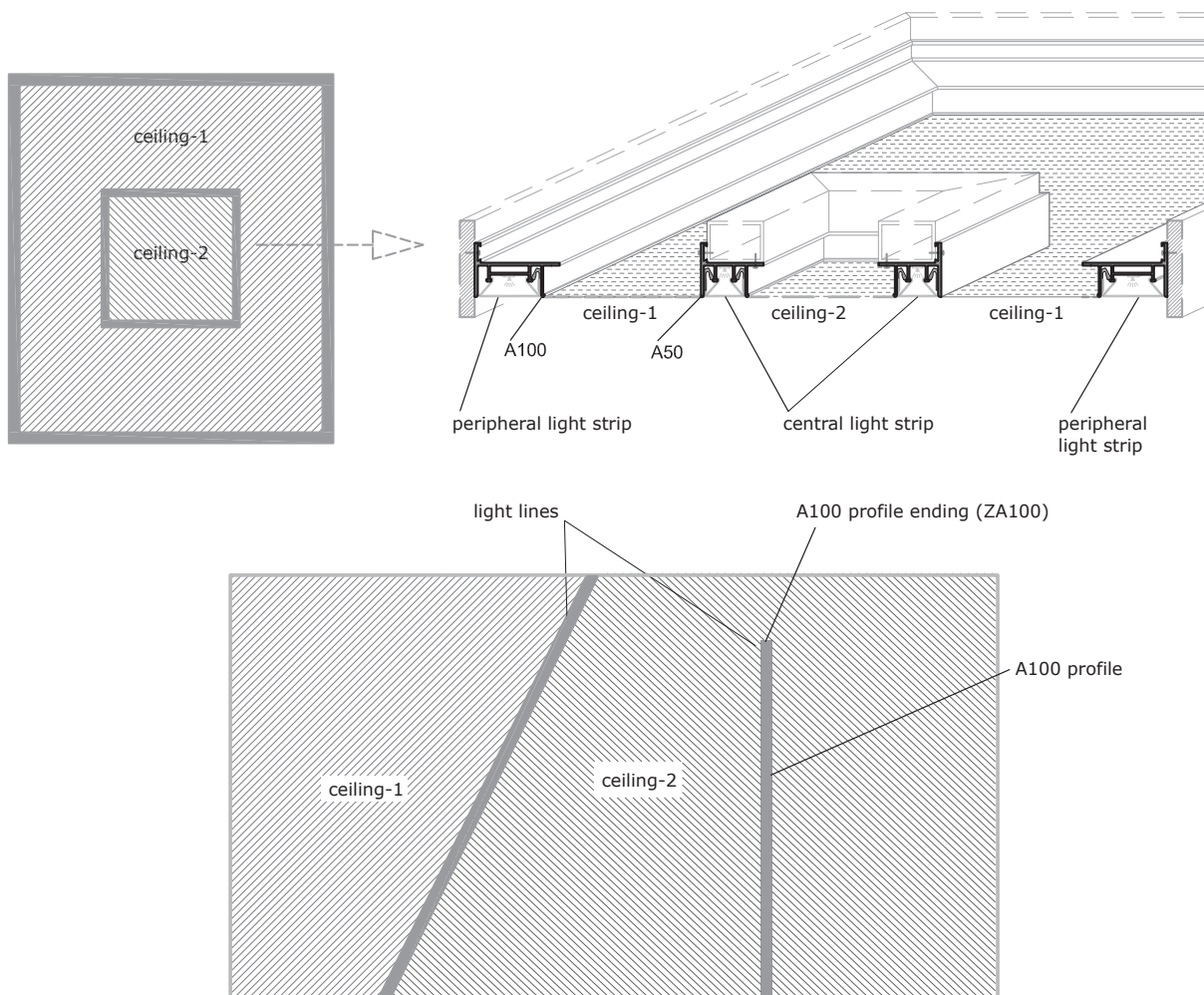

ALX1

BENDING PROFILE

The profile is used to bend stretch ceiling sheets in the SLIM system.

Enables the creation of multi-level or three-dimensional elements.

Upon request, the profile may be powder coated or anodized.

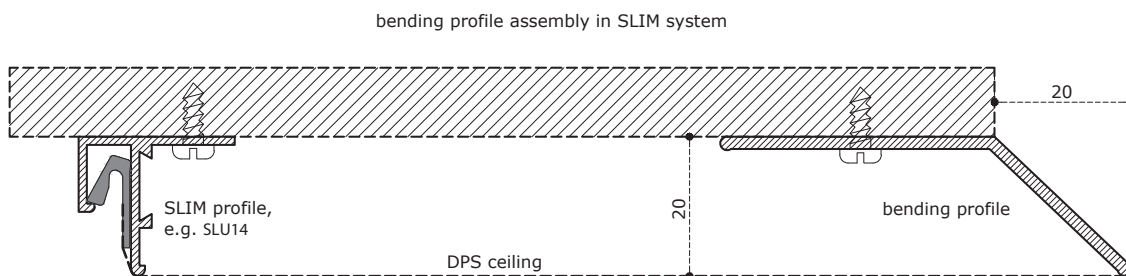
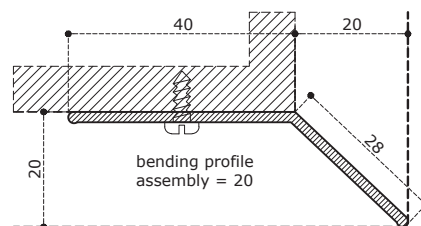

model:	ALX 1 BENDING PROFILE [aluminium 6060 T6]
product code:	ALX1
trading length:	2.5 lm
weight:	0.324 kg/lm
assembly holes:	none
notches:	none
assembly:	wall / ceiling / support structure
compatibility:	SLIM collection

SLIM PROTECTOR

A protective profile attached to the edges of other SLIM collection profiles.

It facilitates the assembly of structure corners and creation of desired angles and bends [easier 3D construction], ensures straight edge lines, maximises profile utilisation [no waste], and provides smooth edges free from structural breaks.

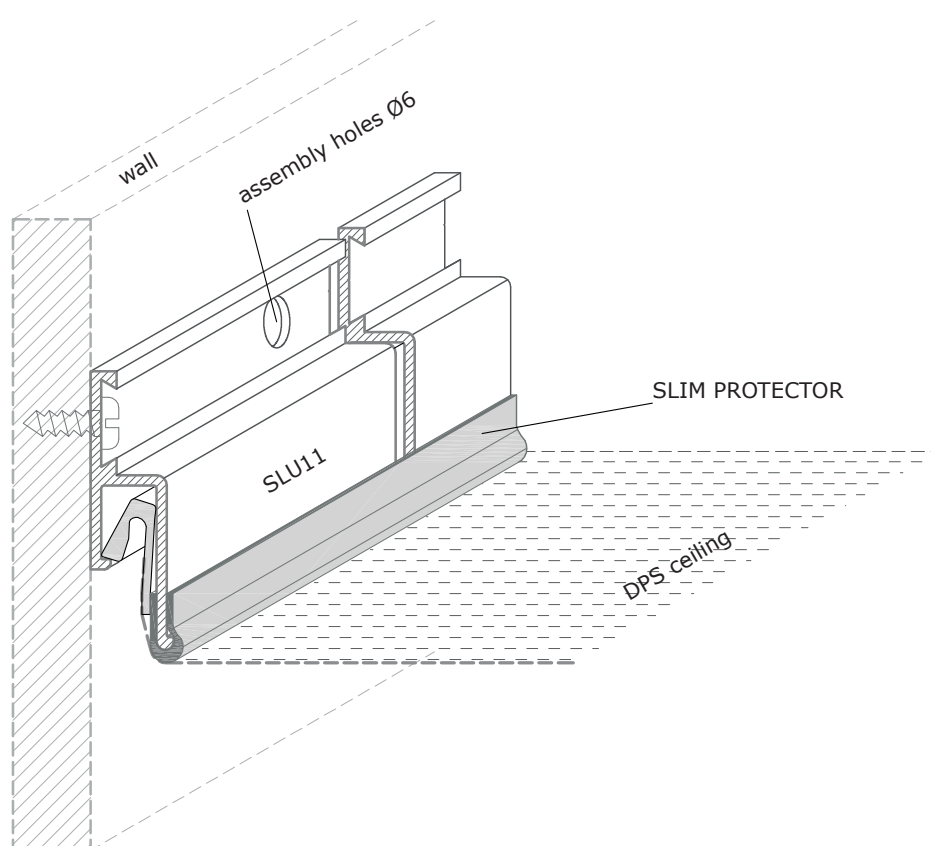
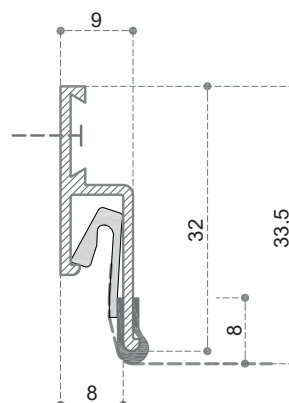

model:	SLIM PROTEKTOR [PVC]
product code:	PSP II
trading length:	2.5 lm
weight:	0.018 kg/lm
assembly holes:	none
notches:	none

EXAMPLES OF CONSTRUCTION WITH SLIM PROTECTOR

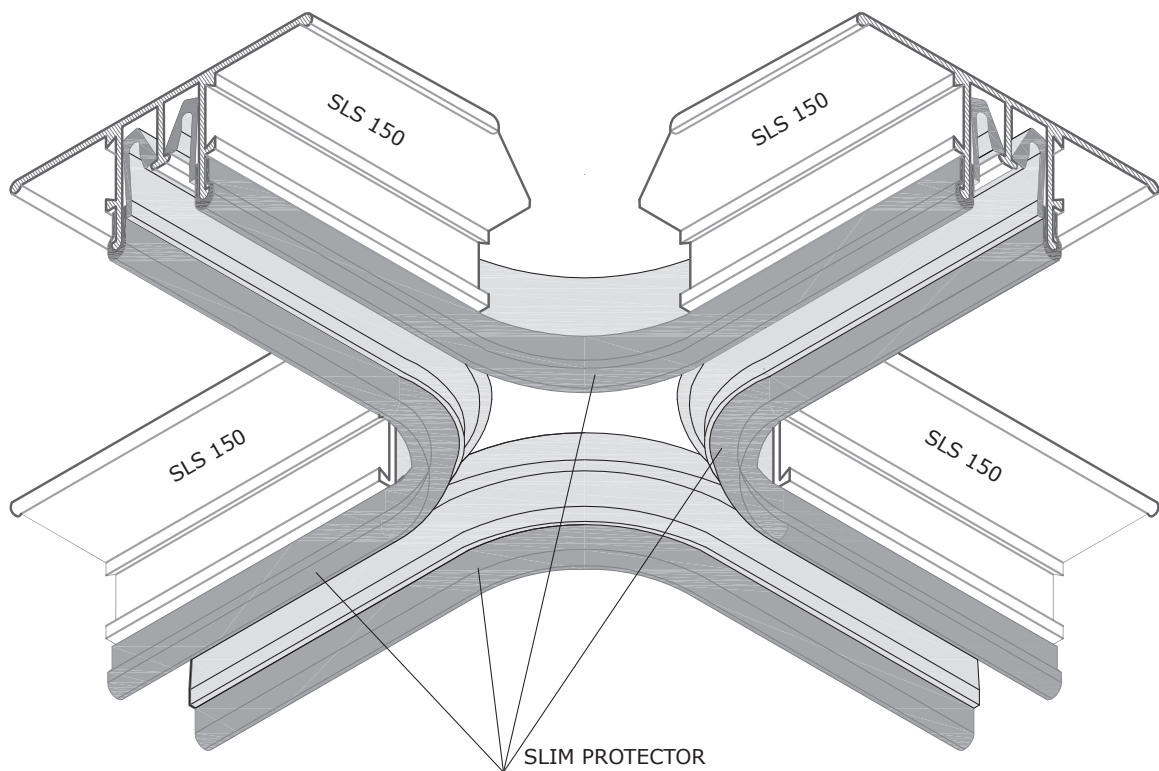
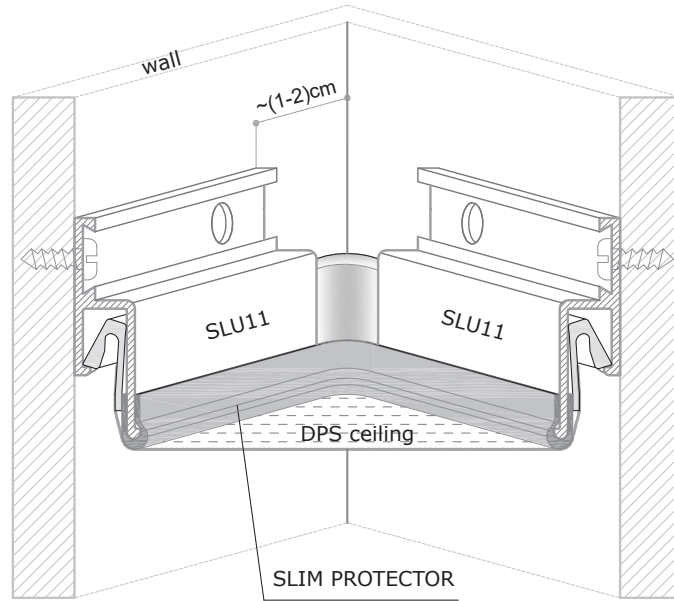

PROFILE LIST

The Wall2Wall profile system is intended for ceilings whose size does not exceed 25m².

The DPS Group cannot be held responsible for misuse of Wall2Wall collection profiles.

PAGE	CROSS-SECTION	MODEL	CODE	DRILL IN		WAVE NOTCHES		CIRCLE NOTCHES	
				CEILING	WALL	2 cm	4 cm	2 cm	4 cm
58		A 01 W2W	A01W2WX000	X	A01W2WW000	X	X	A01W2WWK20	A01W2WWK40
60		A 02 W2W	A02W2WX000	A02W2WC000	X	X	X	X	X
62		A 03 W2W	A03W2WX000	A03W2WC000	X	X	X	X	X
64		A 04 W2W	A04W2WX000	X	X	X	X	X	X
66		A 05 W2W	A05W2WX000	X	X	X	X	X	X
68		A 07 W2W	A07W2WX000	X	X	X	X	X	X
70		S 02 W2W	S02W2WX000	X	X	X	X	X	X
72		PSN 9145	91.45	X	X	X	X	X	X
74		A 09 W2W	A09W2WX000	X	X	X	X	X	X

A 01 W2W

The basic W2W system profile used for assembly on walls or on the side of a supporting structure.

Its plasticity makes it possible to assemble curved sheets of a large radius. For a smaller radius, use notched A01W2WWK20 or A01W2WWK40 profiles.

Upon request, this profile may be powder coated or anodized.

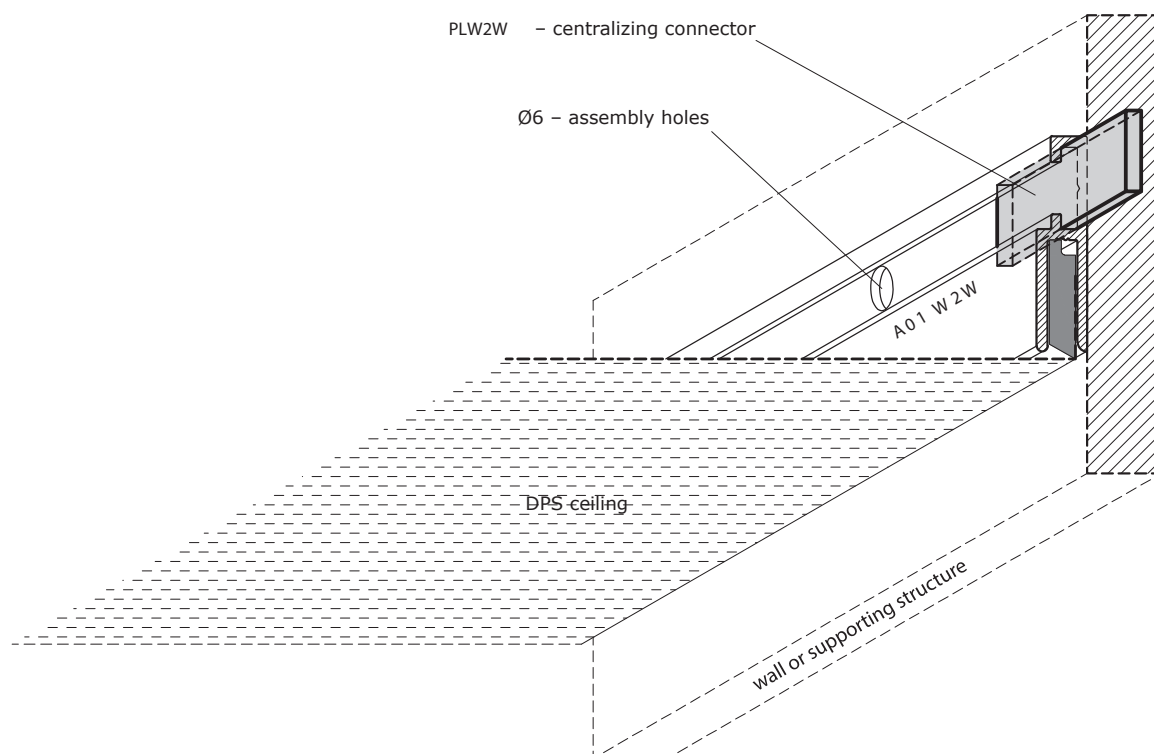
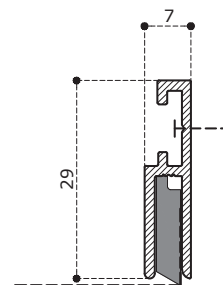

model:	A 01 W2W [aluminium 6060 T6]			
product code:	A01W2WX000	A01W2WW000	A01W2WWK20	A01W2WWK40
trading length:	2.5 lm	2.5 lm	2.5 lm	2.5 lm
weight:	0.216 kg/lm	0.206 kg/lm	0.188 kg/lm	0.198 kg/lm
assembly holes:	none	Ø 6 every 20 cm	Ø 6 every 20 cm	Ø 6 every 20 cm
notches:	none	none	every 2 cm/circle	every 4 cm/circle
assembly:	wall (W)			
compatibility:	W2W harpoon			

RECTANGULAR CEILING

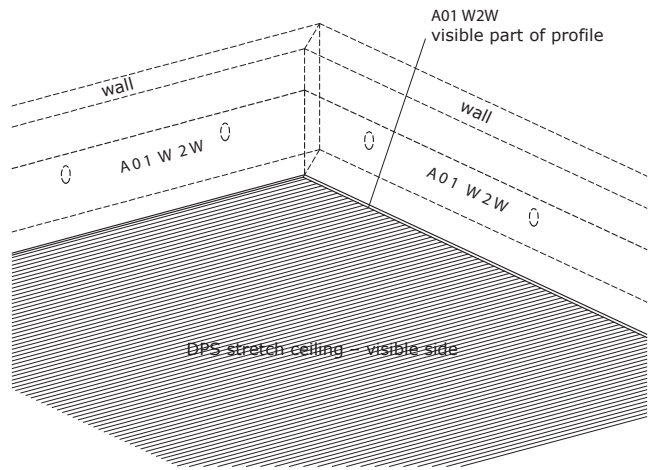
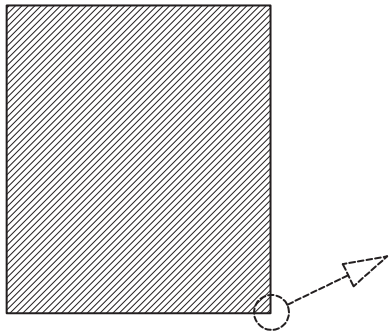

CEILING WITH A CURVED SIDE

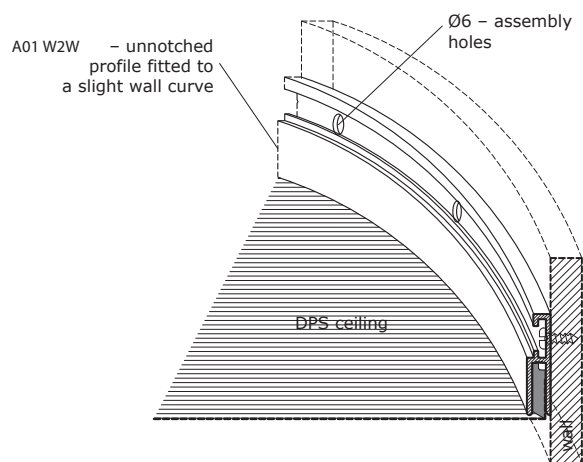
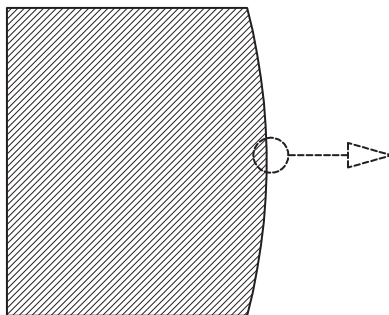

ROUND CEILING OF SMALLER RADIUS

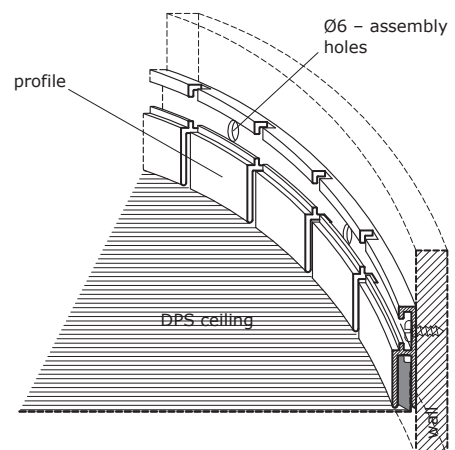
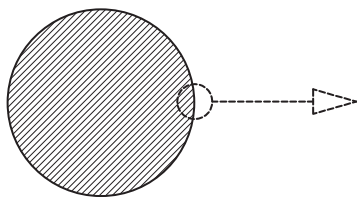

A 02 W2W

This basic profile is used for direct assembly to the ceiling or supporting structure.

Used for ceilings that fill in the entire space of the room, or a part of it in the form of an "island". It is also used to combine several smaller elements that make up the entire ceiling.

We are capable of producing any dimensions of identical elements that are applicable based on the room size.

Upon request, the profile may be powder coated or anodized.

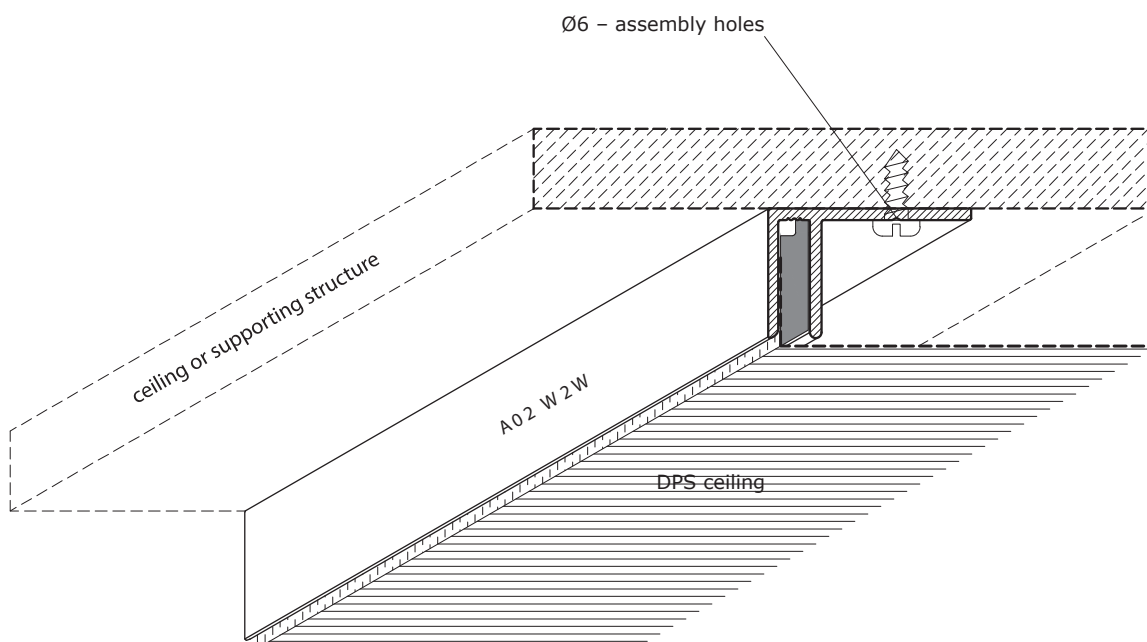
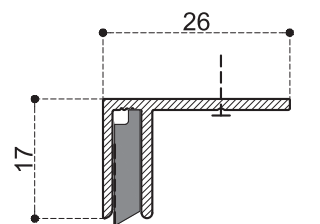

model:	A 02 W2W [aluminium 6060 T6]	
product code:	A02W2WX000	A02W2WC000
trading length:	2.5 lm	2.5 lm
weight:	0.216 kg/lm	0.207 kg/lm
assembly holes:	none	Ø 6 every 20 cm
notches:	none	none
assembly:	ceiling (C)	
compatibility:	W2W harpoon	

RECTANGULAR CEILING [CEILING-ATTACHED PROFILES]

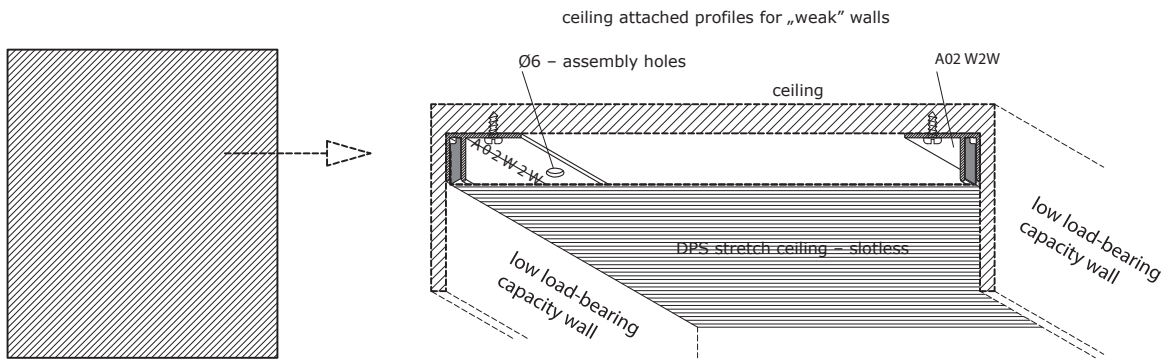

„ISLAND” - TYPE CEILING [CEILING-ATTACHED PROFILES]

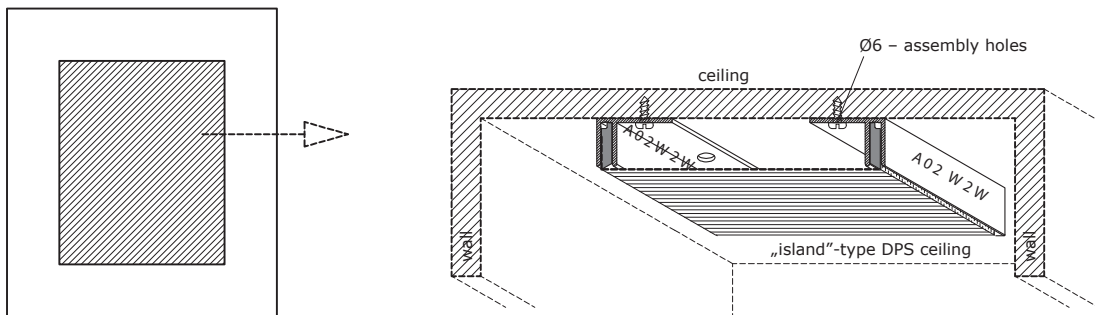

SMALLER “ISLAND” ELEMENTS COMPRISING THE COMPLETE CEILING

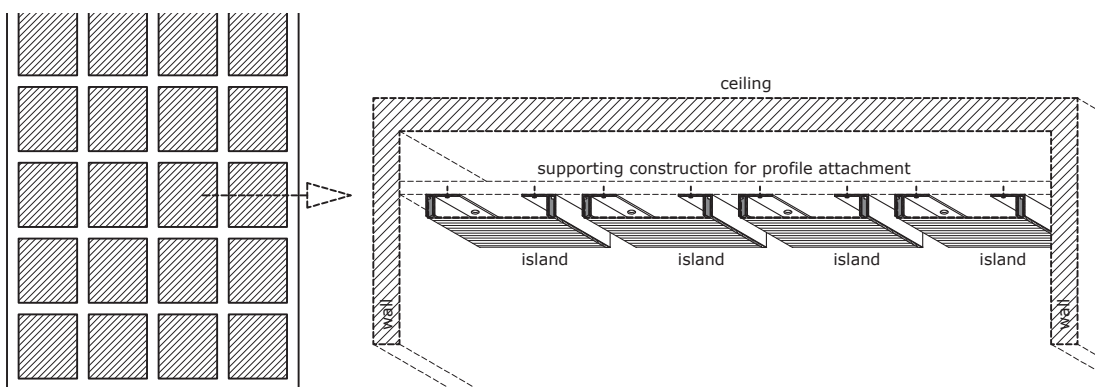

A 03 W2W

A separating system profile.

Used to join stretch ceiling sheets.

This profile may be powder coated or anodized upon request.

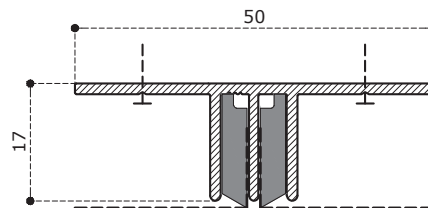

A03 W2W slotless separator

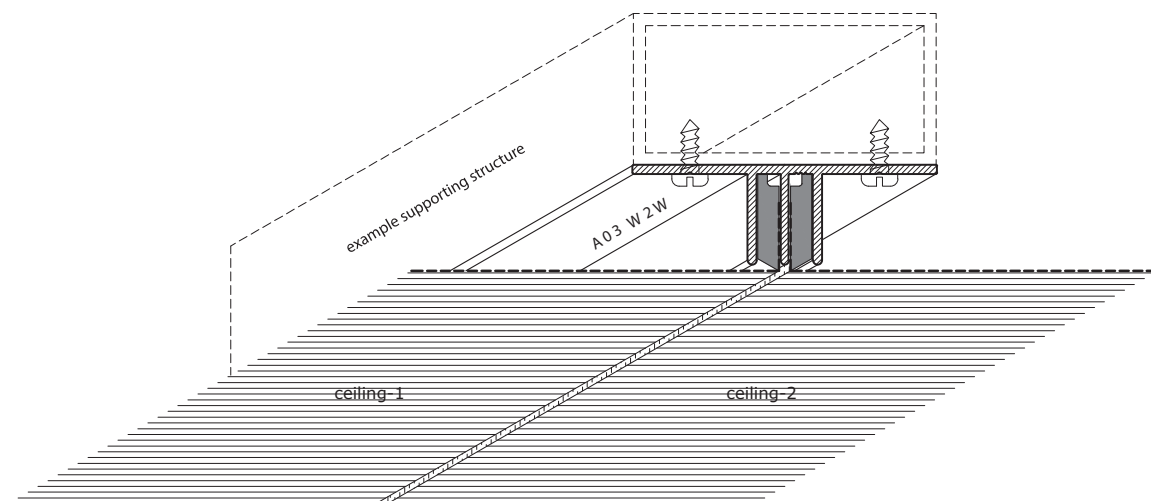

model:	A 03 W2W [aluminium 6060 T6]	
product code:	A03W2WX000	A03W2WC000
trading length:	2.5 lm	2.5 lm
weight:	0.375 kg/lm	0.365 kg/lm
assembly holes:	none	Ø 6 every 20 cm
notches:	none	none
assembly:	ceiling (C)	
compatibility:	W2W harpoon	

SEPARATOR JOINS TWO SHEETS INTO ONE PLAIN

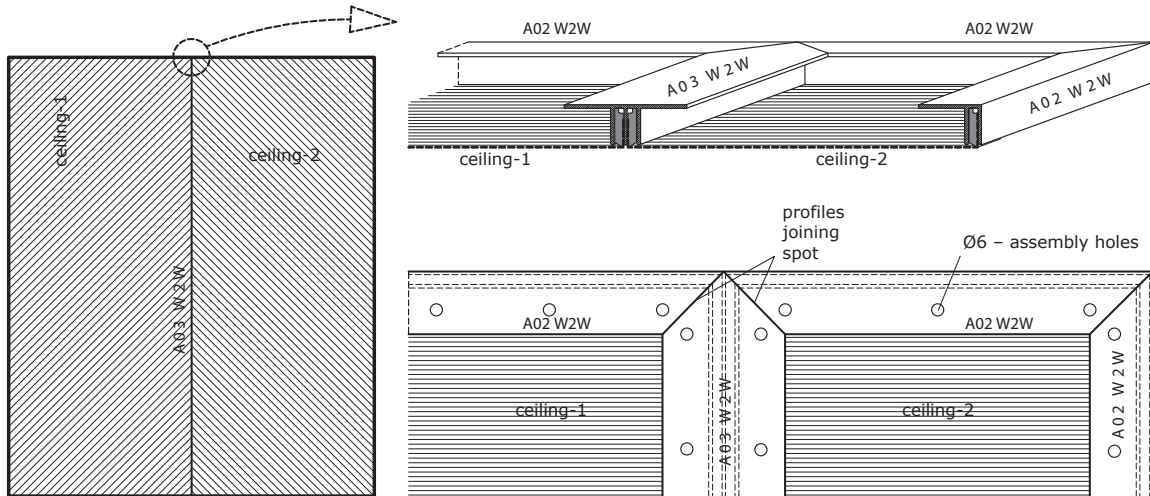

SEPARATORS JOIN FOUR SHEETS INTO ONE PLAIN

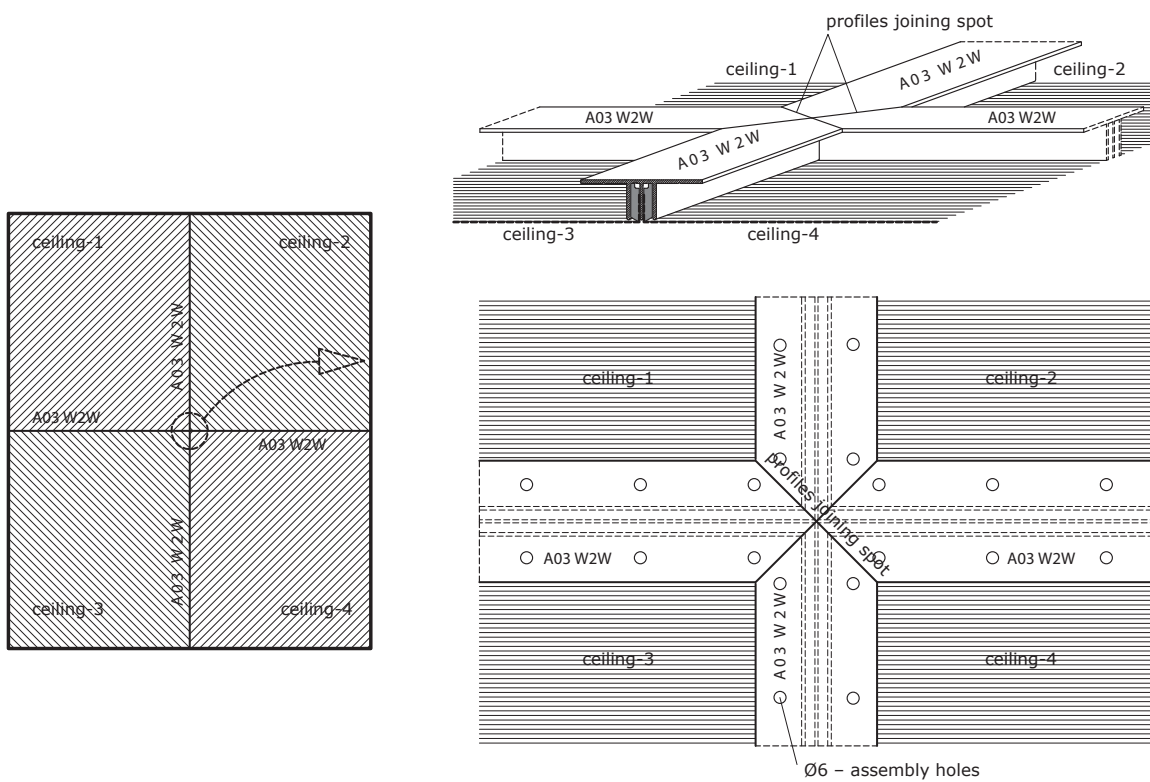

A 04 W2W

This profile is intended for assembly on walls and ceilings. It may be used to create suspended panels.

If attached to a wall, it allows you to create light pictures, presentation screens, etc. [FIG. 1].

The horizontal version enables the creation of suspended elements:

- light panels [FIG. 2]
- acoustic panels [FIG. 3]
- ceiling panels with thermic barrier [FIG. 4]

Upon request, the profile may be anodized, brushed or powder coated. It may be also cut to size.

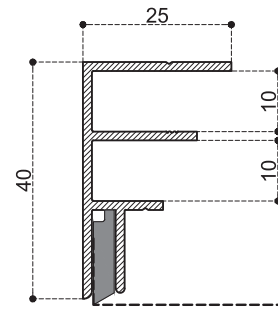
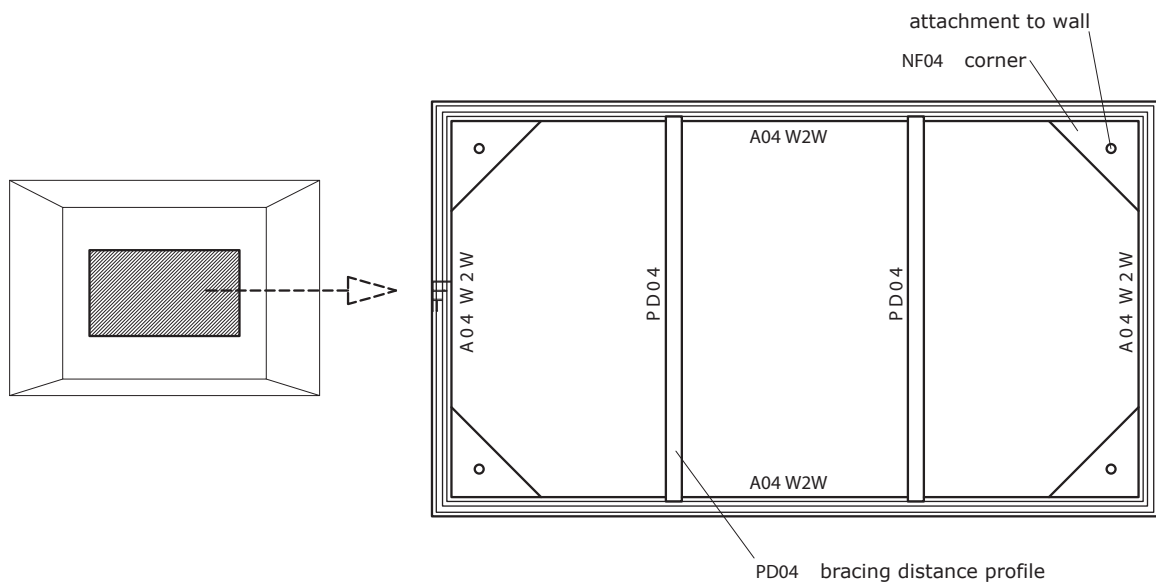

FIG. 1 | PROJECTOR SCREEN



model:	A 04 W2W [aluminium 6060 T6]
product code:	A04W2WX000
trading length:	2.5 lm
weight:	0.431 kg/lm
assembly holes:	none
notches:	none
assembly:	the possibility of bending must be agreed prior to ordering
compatibility:	W2W harpoon

FIG. 2 | LIGHT PANEL

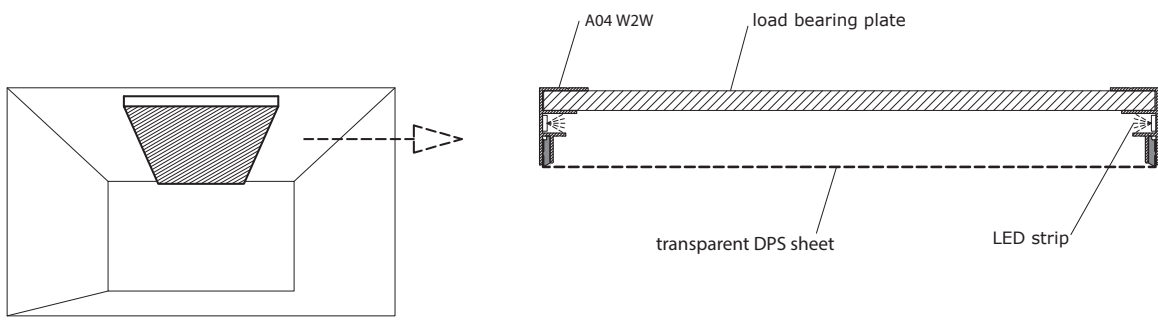

FIG. 3 | ACOUSTIC PANELS

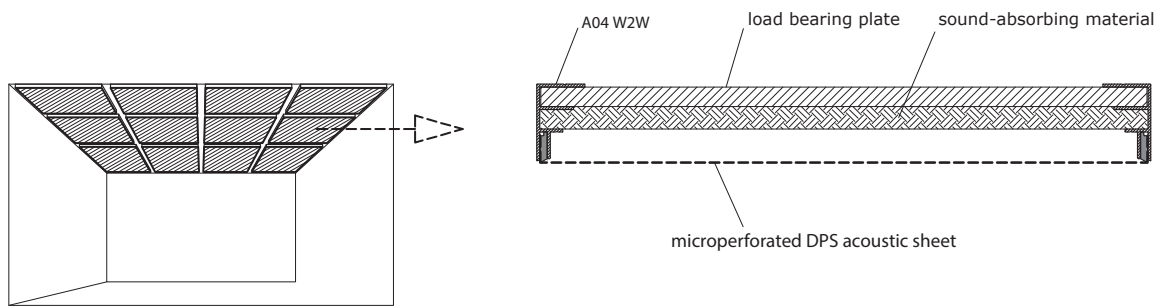
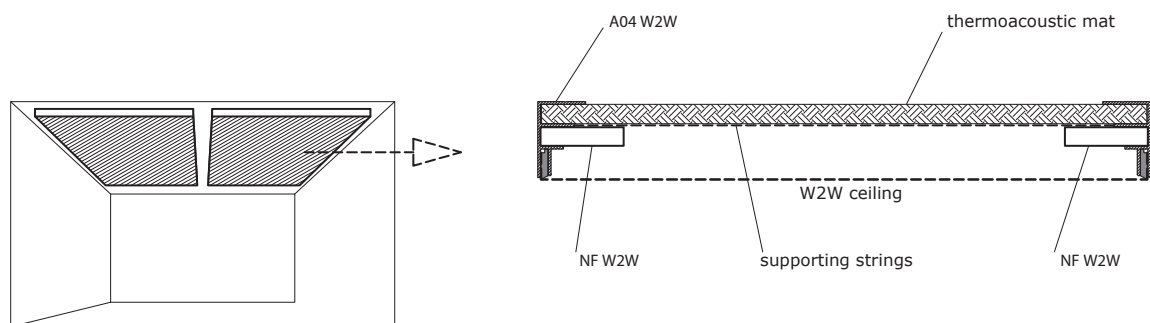

FIG. 4 | CEILING PANELS WITH THERMAL BARRIER



A 05 W2W

This profile is used for round, elliptic, oval or arch-shaped forms.

It makes it possible to create light [FIG.1], acoustic [FIG2], advertising or utility elements.

Twin elements may be join to obtain higher elements, e.g. 16 cm, 24 cm, etc. [FIG. 3]. The elements may be hung or attached to the ceiling.

Upon request, the profile may be powder coated or anodized. It is recommended to use dedicated light sources [ask your commercial assistant].

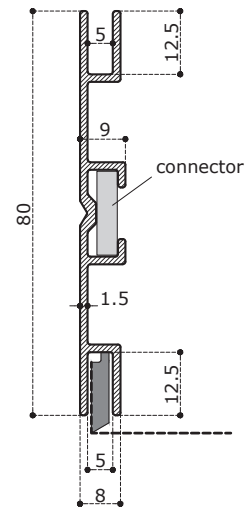
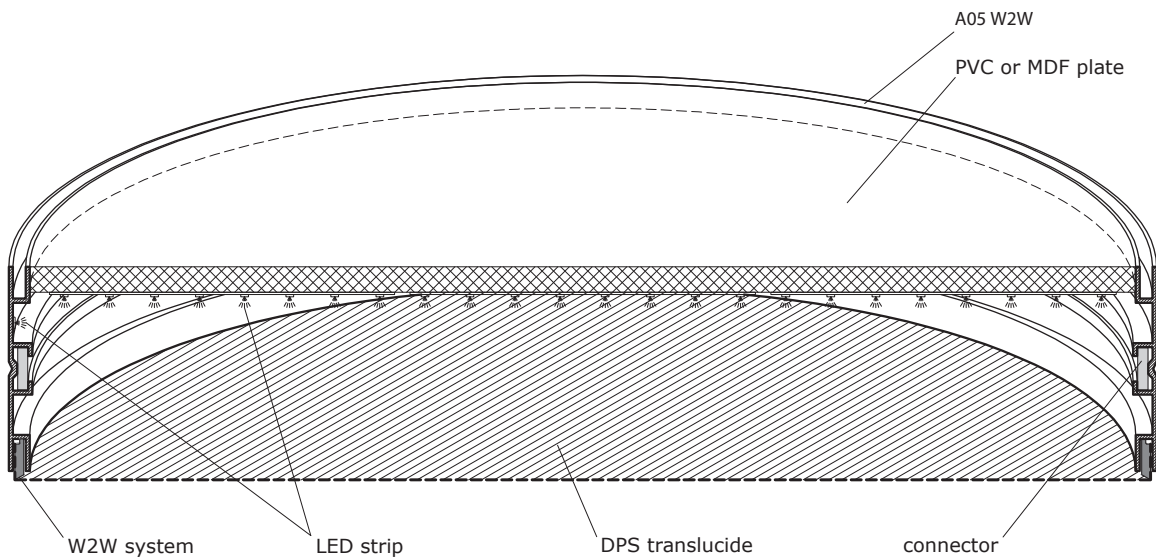

FIG. 1 | LIGHT ELEMENT



model:	A 05 W2W [aluminium 6060 T6]
product code:	A05W2WX000
trading length:	4.0 lm
weight:	0.587 kg/lm
assembly holes:	none
bending*:	circle / ellipse
compatibility:	W2W harpoon
comments:	*maximum diameter of free-hanging elements: 2lm; larger diameters subject to agreement

FIG. 2 | ACOUSTIC ELEMENTS

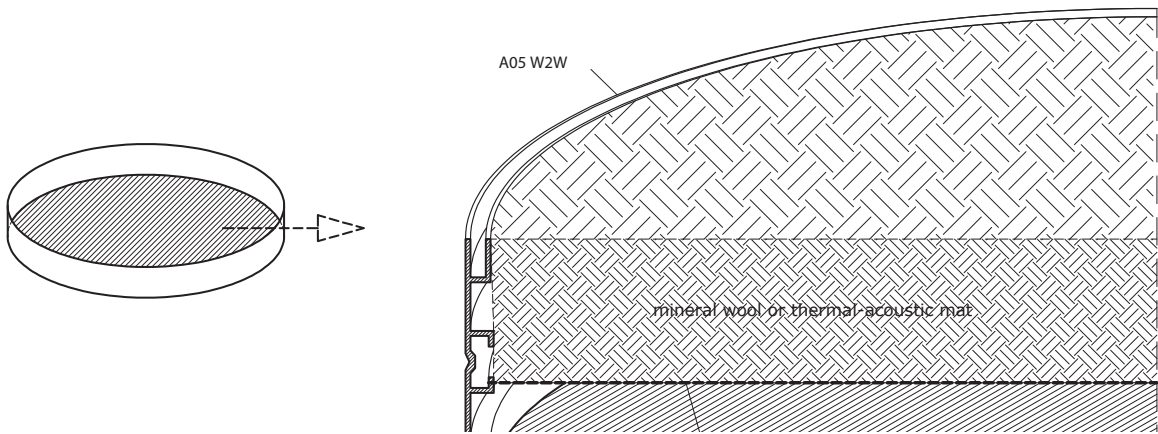
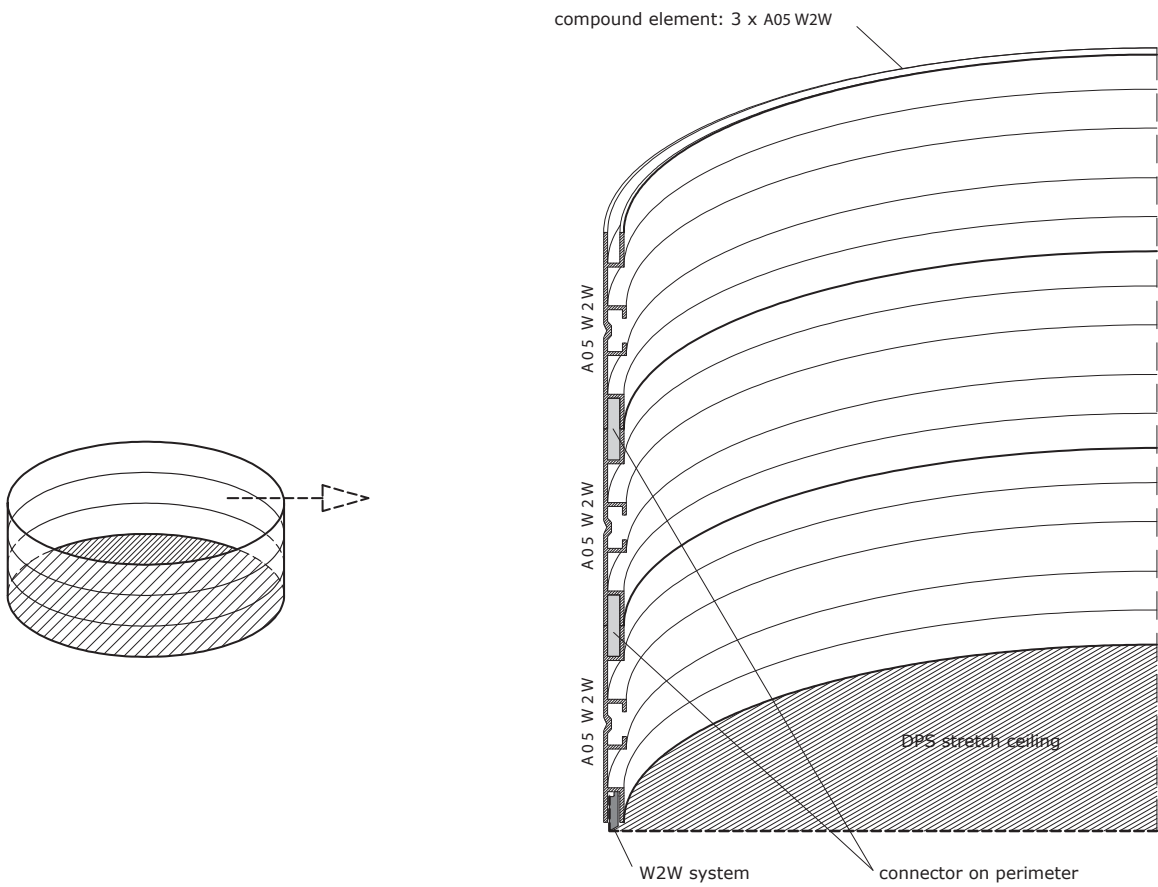

FIG. 3 | ADDING HEIGHT



A 07 W2W

The A07 W2W profile is used for rectangular, circular or elliptic lighting, acoustic and commercial elements.

Upon request, the profile may be anodized, brushed or powder coated.

It is recommended to use dedicated light sources and acoustic materials [ask your commercial assistant].

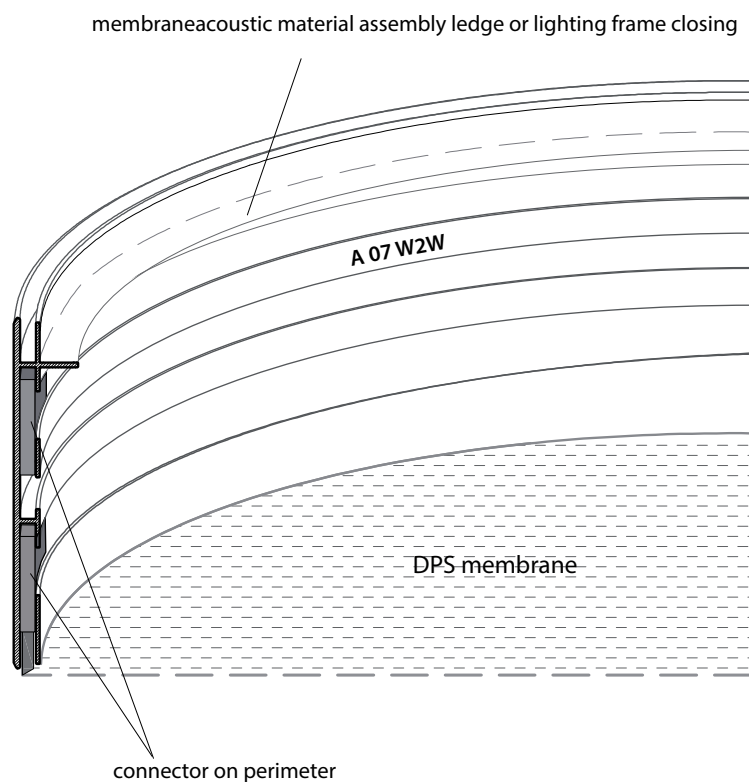
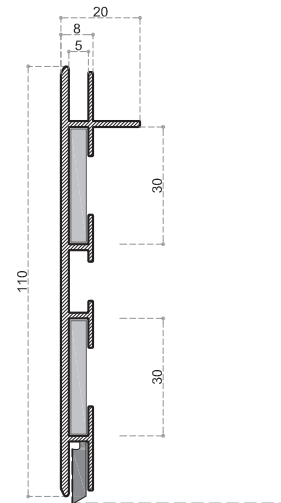

model:	A 07 W2W [aluminium 6060 T6]
product code:	A07W2WX000
trading length:	5.0 lm
weight:	0.924 kg/lm
assembly holes:	none
bending*:	circle / ellipse
compatibility:	W2W harpoon
comments:	*the shape and size of the element should be agreed with the commercial assistant

ACOUSTIC COMPONENT

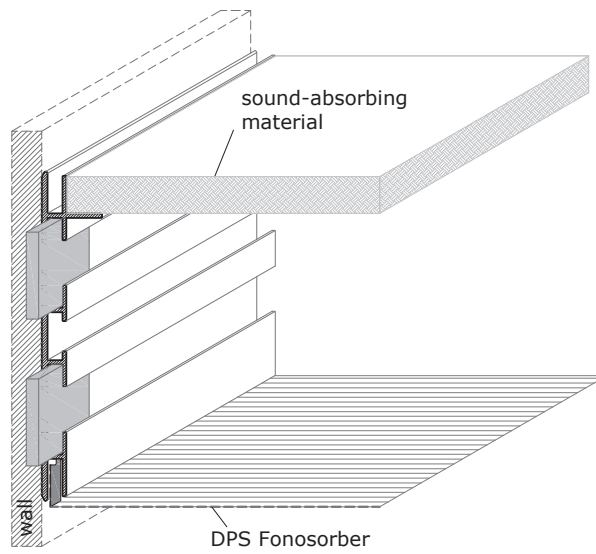

LIGHT COMPONENT

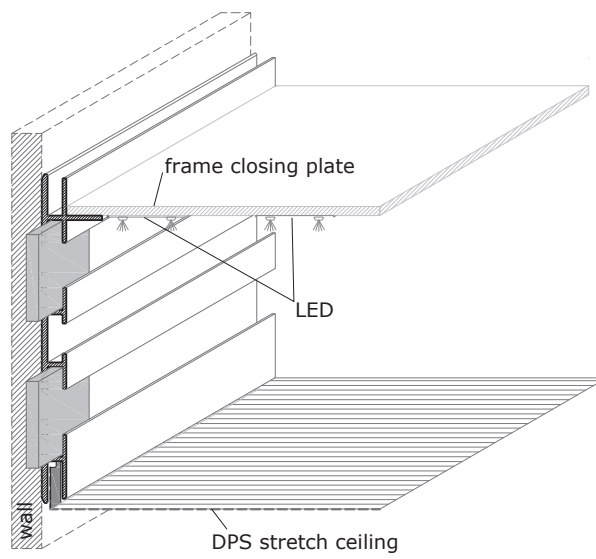

ACOUSTIC-LIGHT COMPONENT

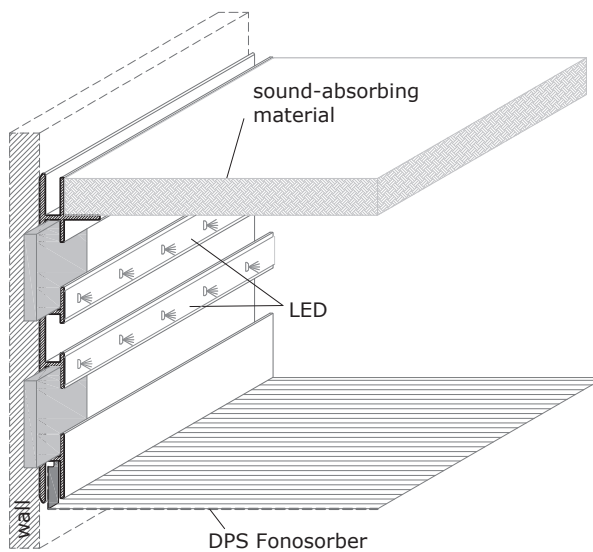

S 02 W2W

A profile used for:

- decorative light covers [FIG. 1]
- decorative suspended panels [FIG. 2]
- suspended acoustic panels both vertical and horizontal [FIG. 3]
- sound-absorbing partition walls

It is also possible to make panels with a thermal mat that serve as a thermal barrier [FIG. 4].

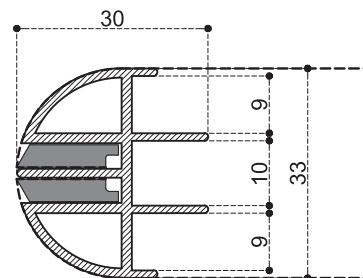
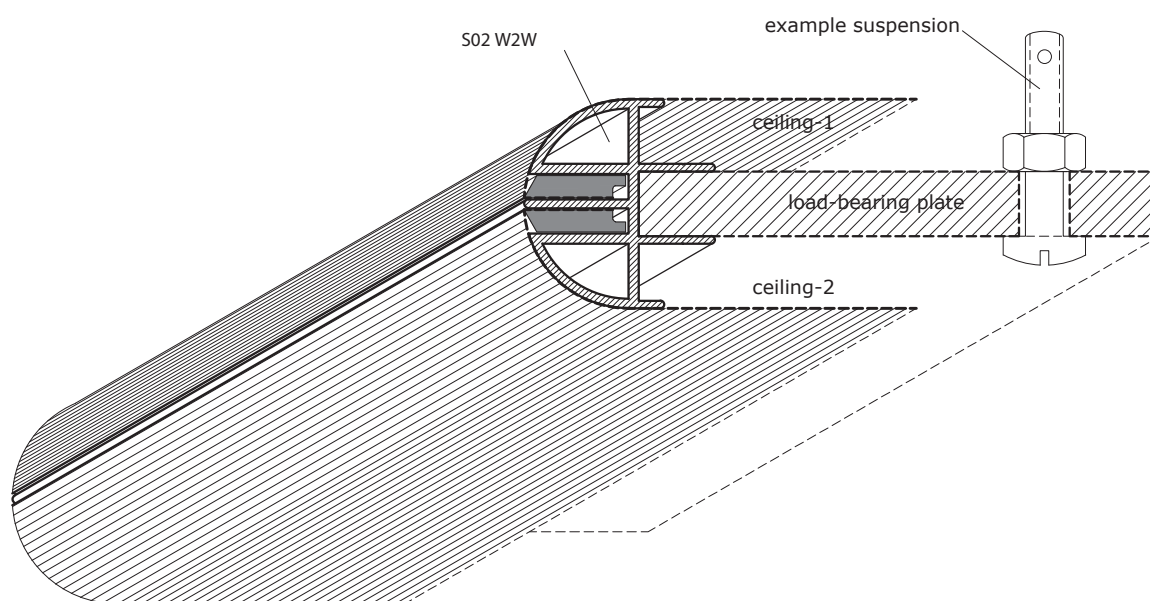

FIG. 1



model:	S 02 W2W [aluminium 6060 T6]
product code:	S02W2WX000
trading length:	5.0 lm
weight:	0.588 kg/lm
assembly holes:	none
bending*:	circle / ellipse
compatibility:	W2W harpoon
comments:	*the shape and size of the element should be agreed with the commercial assistant

FIG. 2 | ONE OR TWO LIGHT PANELS

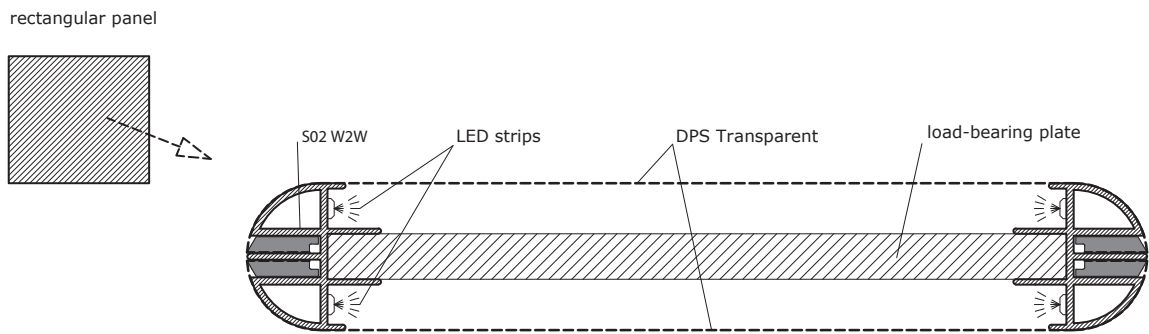

FIG. 3 | VERTICAL OR HORIZONTAL ACOUSTIC PANEL

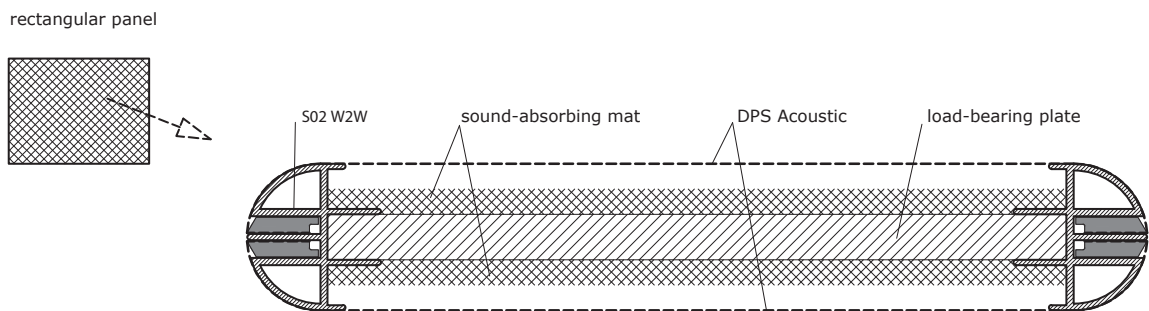
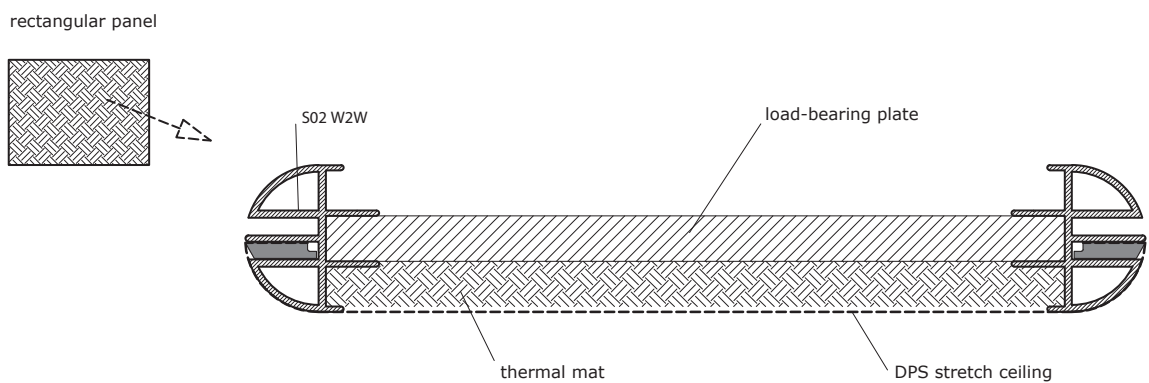

FIG. 4 | THERMAL INSULATION PANEL



PSN 9145

A high-rigidity profile, designed for the construction of free-hanging square or rectangular elements as a frame for:

- large-format lighting [fig.1]
- acoustic panels [fig.2]
- separate ceiling panels [fig.3]
- integrated panels [fig.4]
- advertising and decorative panels [fig.5].

The installation gap is about 1 mm.

Upon request, the profile may be powder coated or anodized.

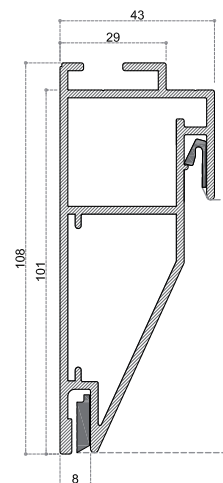
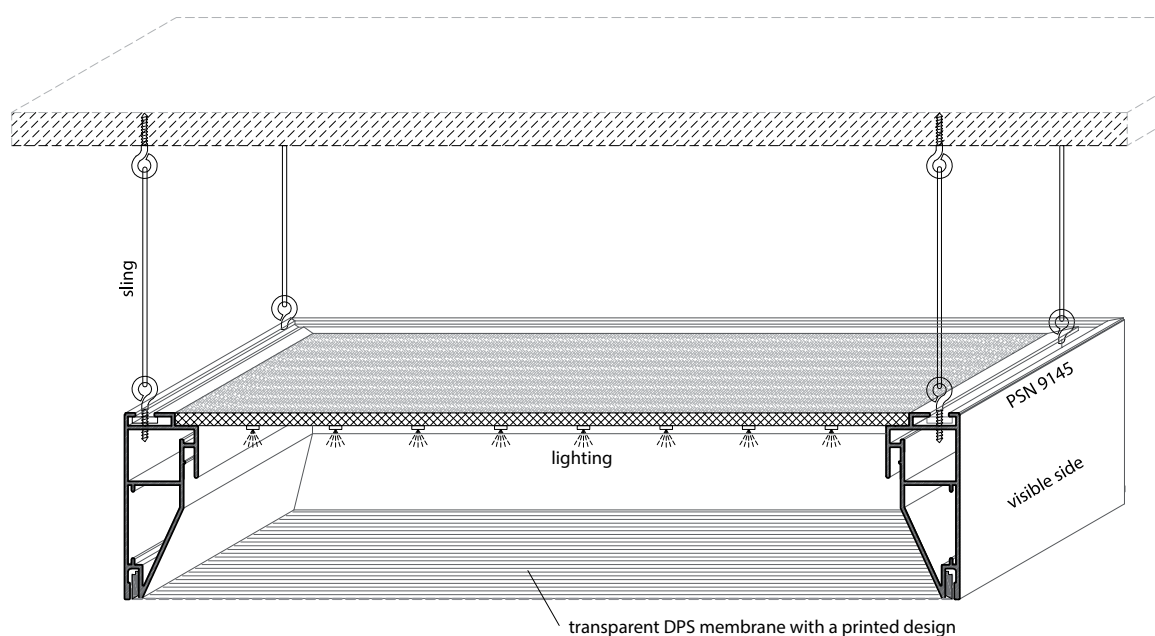

FIG. 1 | LIGHTING OR ADVERTISING PANEL



model:	PSN 9145 [aluminium 6060 T6]
product code:	91.45
material:	aluminium 6060 T6
trading length:	5.0 lm
weight:	1.92 kg/lm
assembly holes:	none
notches:	none
bending:	no
compatibility:	alu harpoon, W2W

FIG 2. | ACOUSTIC PANEL

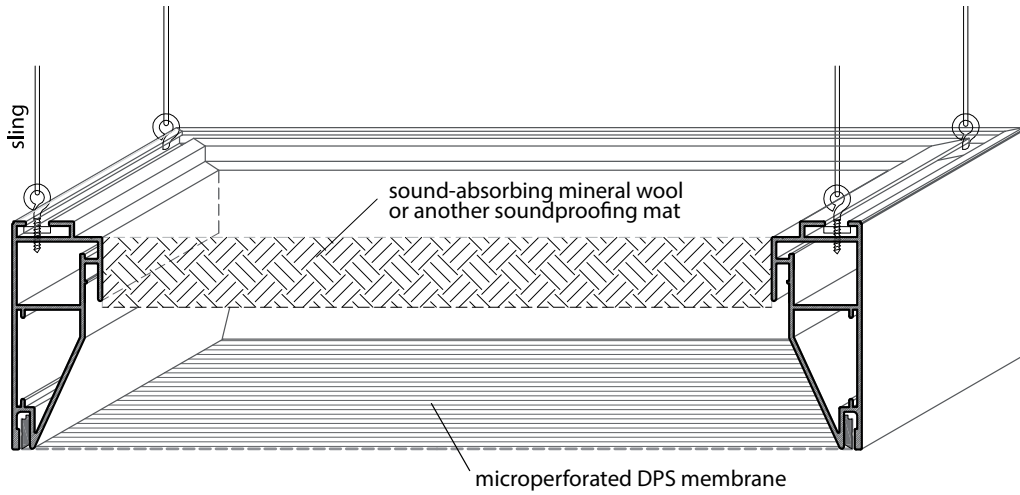

FIG 3. | SEPARATE PANEL - CEILING OR WALL ASSEMBLY

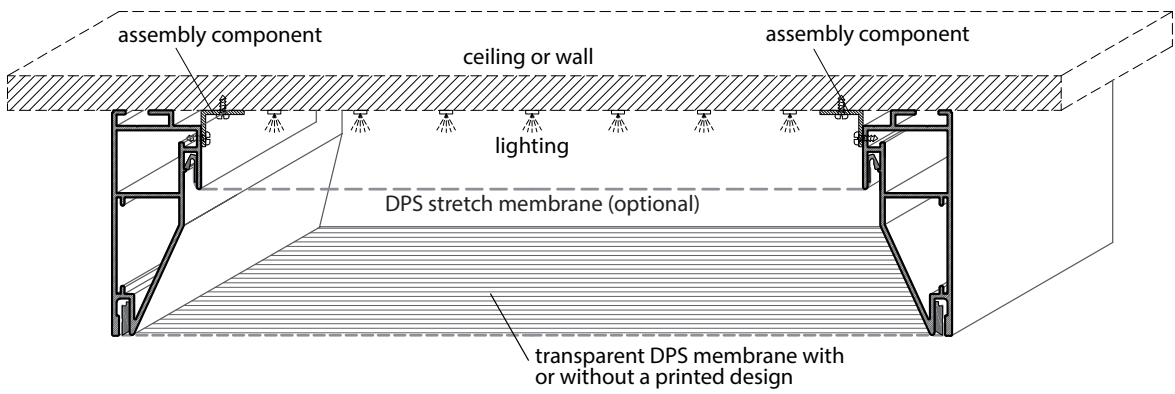

FIG. 4 | INTEGRATED PANELS

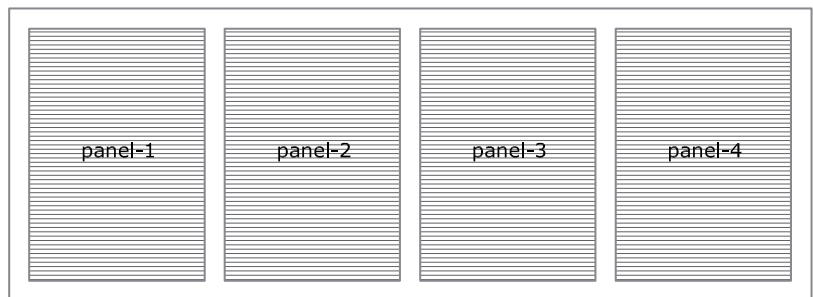
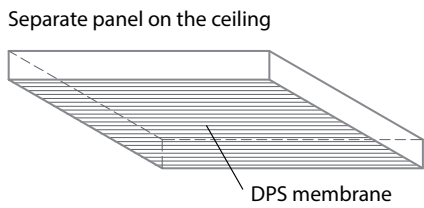
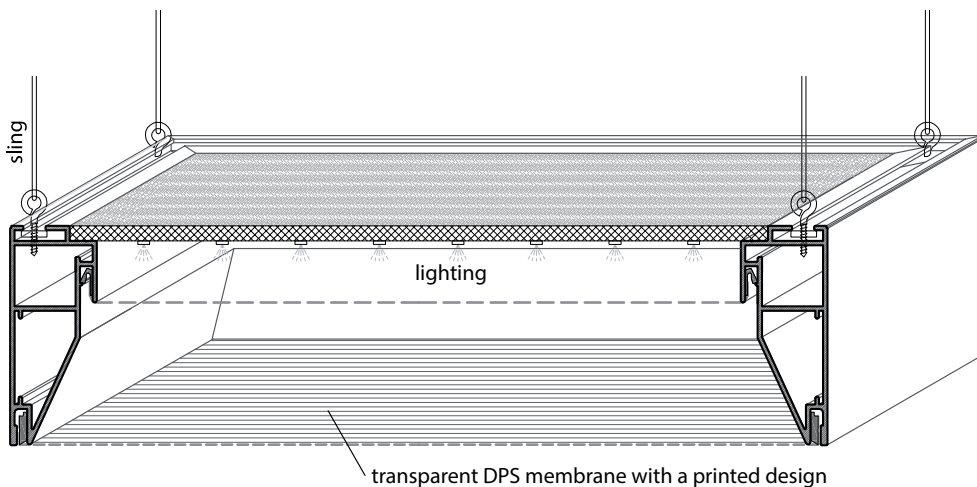

FIG.5 | ADVERTISING OR DECORATIVE PANEL



A 09 W2W

A profile designed for the installation of stretch ceilings to illuminate interiors with solar or LED light. Its special design allows the installation of an additional protective membrane without the need for an additional mounting profile.

It makes it possible to create: light, acoustic, advertising and utility elements.

Upon request, the profile may be powder coated or anodized.

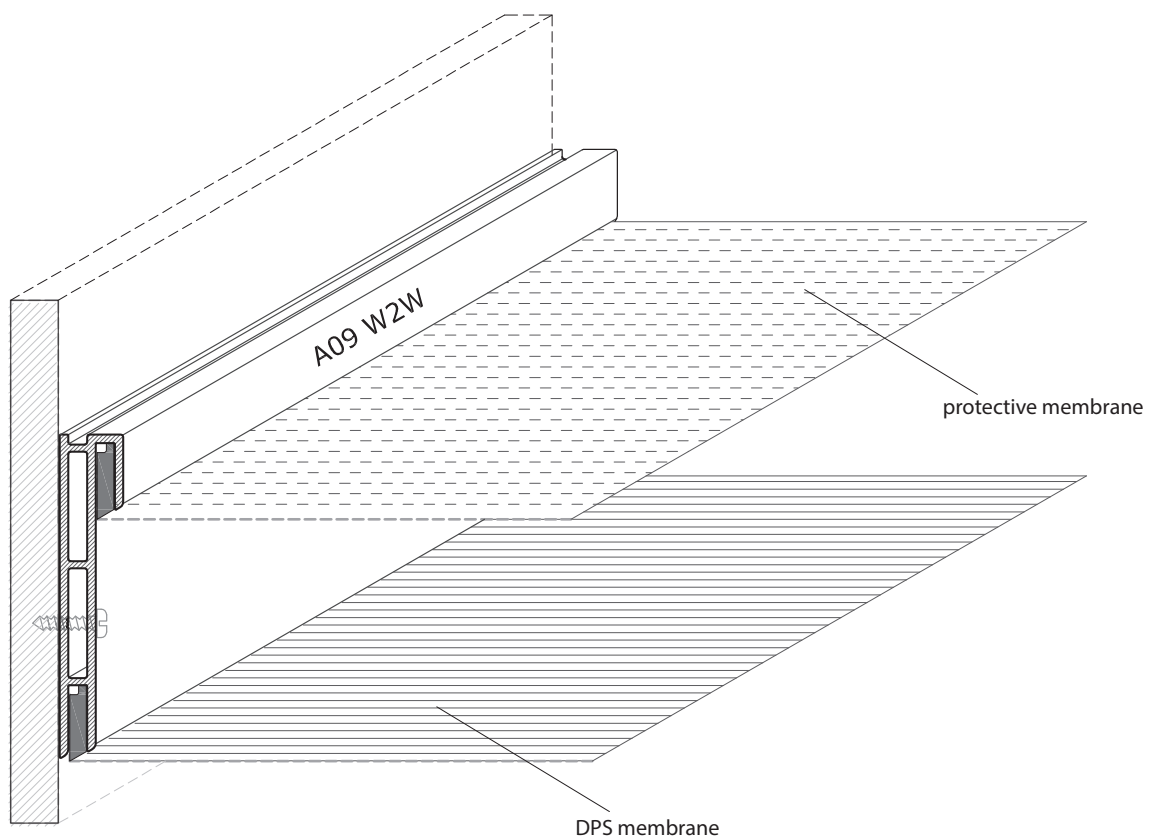
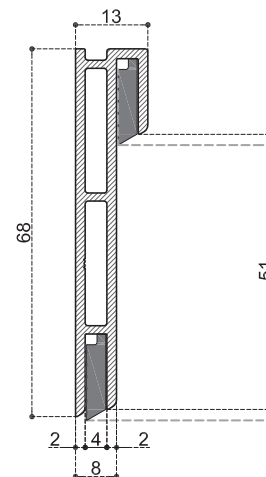



- model: **A 09 W2W** [aluminium 6060 T6]
- product code: **A09W2WX000**
- trading length: **5,0 mb**
- weight: **0,803 kg/mb**
- assembly holes: **none**
- bending: **no**
- compatibility: **W2W harpoon**

TRENDERO COLLECTION

PROFILE LIST

The TENDERO profile system is designed for the assembly of textile and PVC walls and ceilings without a harpoon.

The DPS Group shall not be held liable for misuse of TRENDERO profiles.

PAGE	CROSS-SECTION	MODEL	COLOUR		WAVE NOTCHES		CIRCLE NOTCHES	
			WHITE	BLACK	3 cm	5 cm	3 cm	5 cm
78		TR PEPLX	TRPEPLX	TRPEPLX B	X	X	X	X
79		TR PPLX	TRPPLX	TRPPLX B	X	X	X	X

TR PEPLX

A PVC profile used to attach the harpoonless Trendero ceilings and walls.

Dedicated for textile materials from the Trendero collection and DPS foil membranes.

It is highly flexible, enabling precise manipulation to fit the surface it is mounted on. Thanks to the elastic PVC, even the smallest gap between the wall and the profile can be eliminated.

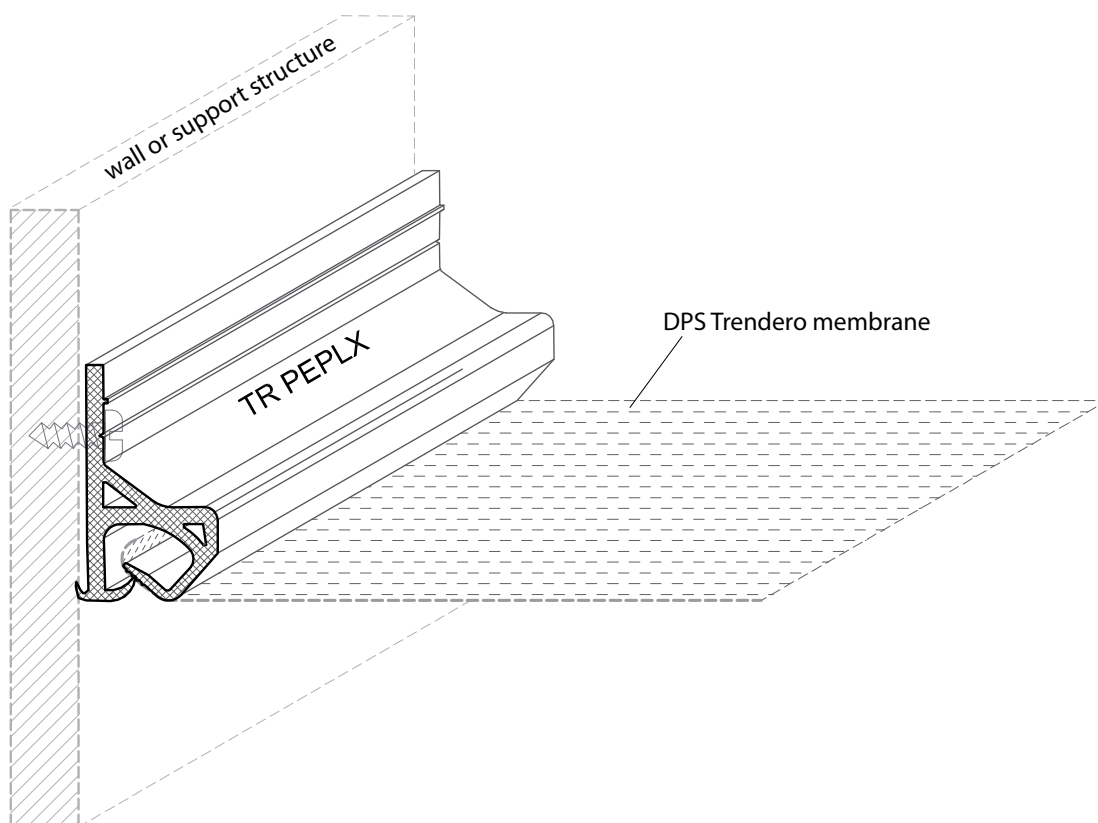
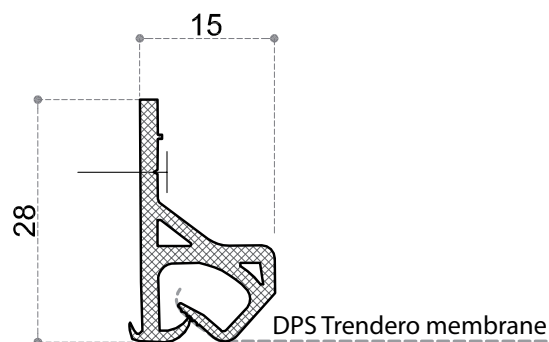

model:	TR PEPLX [PVC]	TR PEPLX [PVC]
product code:	TRPEPLX	TRPEPLX B
trading length:	2.0 lm	2.0 lm
weight:	0.225 kg/lm	0.225 kg/lm
assembly holes:	Ø 5 every 15 cm	Ø 5 every 15 cm
notches:	none	none
comments*:	white colour	black colour
compatibility:	DPS Trendero	DPS Trendero

TR PPLX

PVC profile for the installation of the Trendero harpoonless ceiling and wall system. Designed for the installation of textiles from the Trendero range and DPS membranes.

Its advantage is that it can be bent to fit precisely to the installation surface. Thanks to the soft PVC, the smallest gap between the profile and the wall is covered.

The profile can be notched by the installer during installation to create curves and circles. The smallest radius is approximately 20 cm.

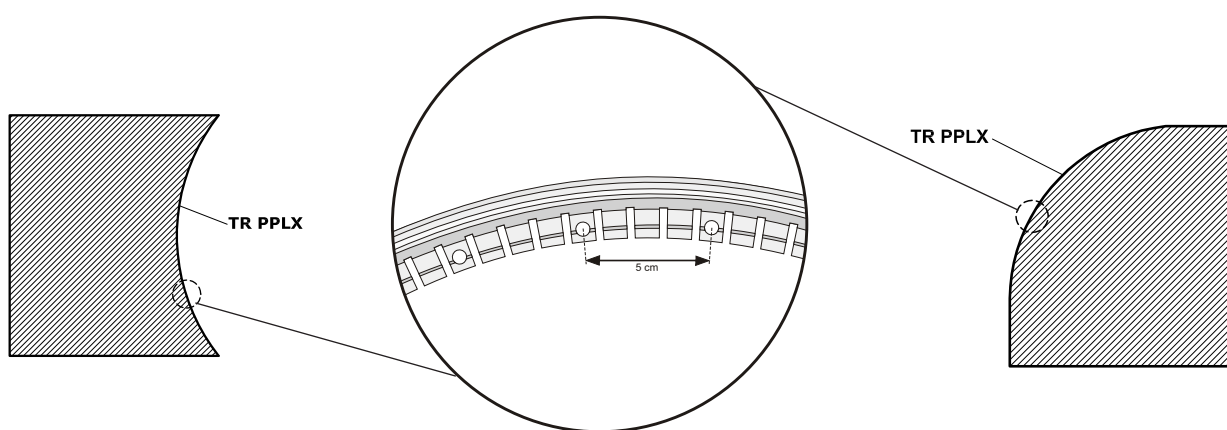
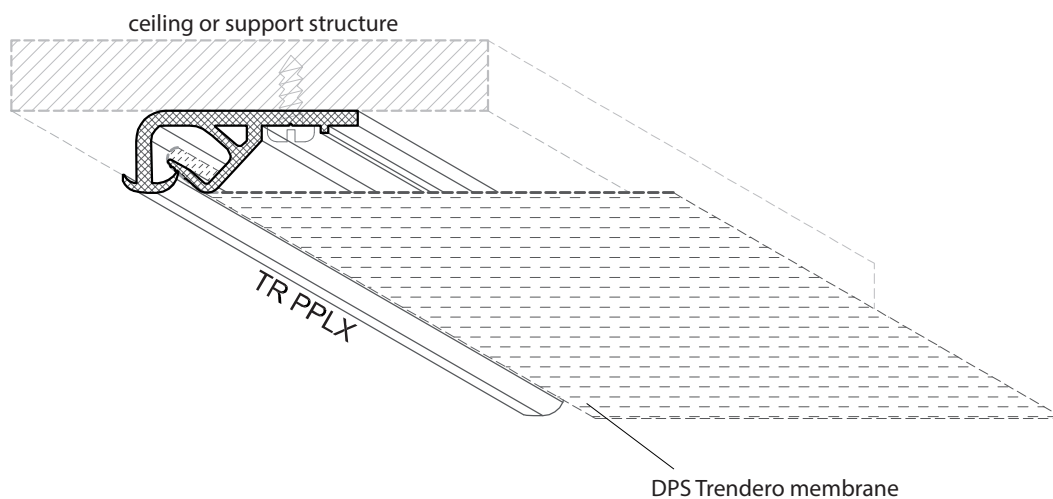
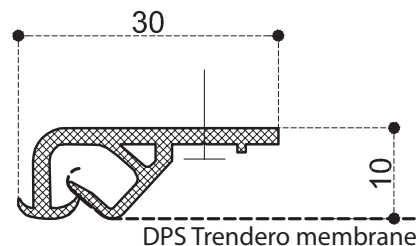

model:	TR PPLX [PVC]	TR PPLX [PVC]
product code:	TRPPLX	TRPPLX B
trading length:	2.0 lm	2.0 lm
weight:	0.200 kg/lm	0.200 kg/lm
assembly holes:	Ø 5 every 15 cm	Ø 5 every 15 cm
notches:	none	none
comments*:	white colour	black colour
compatibility:	DPS Trendero	DPS Trendero

CEILING ACCESSORIES

name: **STRAIGHT CONNECTOR TO STANDARD SYSTEM**
product code: **PLLU**
material: **hard PVC**
sales unit: **piece**

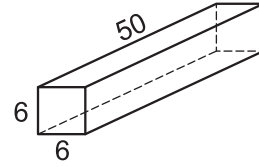

name: **STRAIGHT CONNECTOR TO SLIM SYSTEM**
product code: **PLSLU**
material: **hard PVC**
sales unit: **piece**

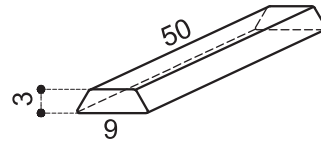

name: **CONNECTOR TO A100 PROFILE**
product code: **PLSL**
material: **polycarbonate**
sales unit: **piece**

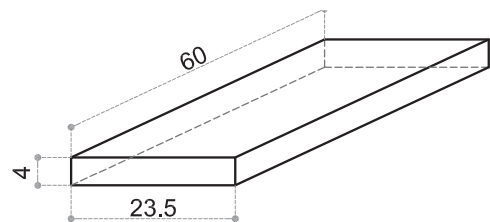

name: **STRAIGHT CONNECTOR TO W2W SYSTEM**
product code: **PLW2W**
material: **aluminium**
sales unit: **piece**

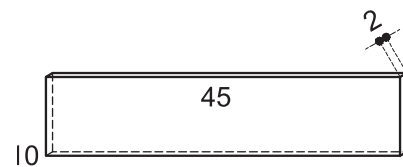

CEILING ACCESSORIES

name: **CORNER CONNECTOR TO W2W SYSTEM**
 product code: **KLW2W**
 material: **aluminium**
 sales unit: **piece**

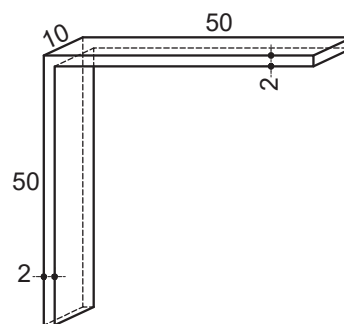

name: **DISTANCE PROFILE FOR A 50 PROFILE**
 product code: **PD200SL**
 material: **hard PVC**
 sales unit: **2.0 lm / piece**

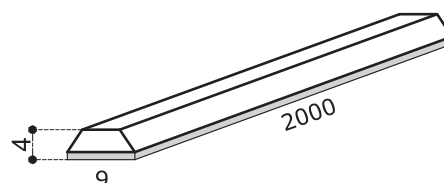

name: **CORNER CONNECTOR TO PSN-LMP PROFILE**
 product code: **LPC95**
 material: **aluminium**
 sales unit: **piece**

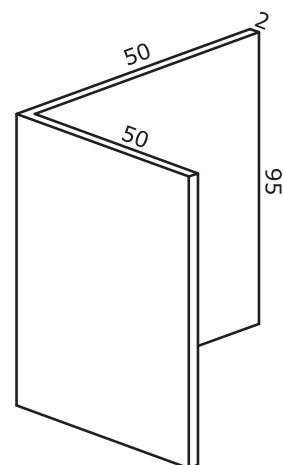

name: **CORNER CONNECTOR TO PSN-LM PROFILE**
 product code: **LPC76**
 material: **aluminium**
 sales unit: **piece**

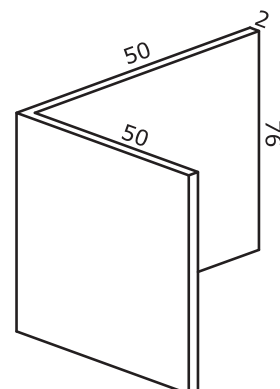

CEILING ACCESSORIES

name: **CORNER PROFILE FOR A 04 W2W**
 product code: KL04W2W
 material: aluminium | pipe 10 x 20 x 1.5
 sales unit: piece

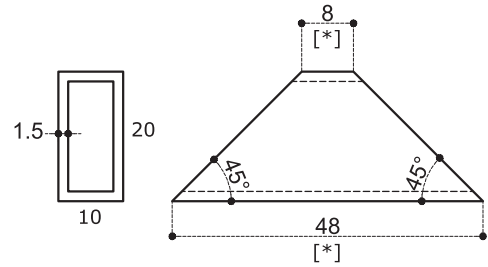

name: **DISTANCE PROFILE FOR A 04 W2W PROFILE**
 product code: PD04W2W
 material: aluminium | pipe pr. 10 x 20 x 1.5
 sales unit: 6 lm (can be cut to size)

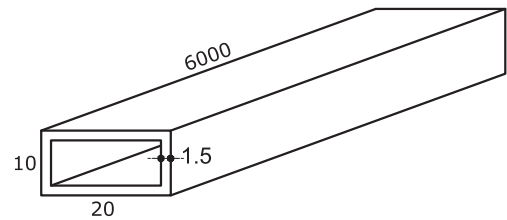

name: **STRAIGHT CONNECTOR TO PSN-LMP**
 product code: PLLMP
 material: wood
 sales unit: piece

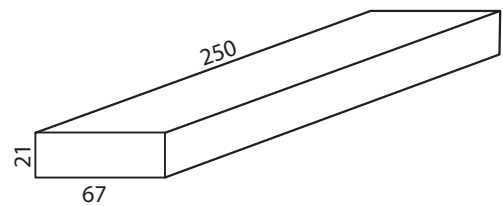

name: **A100 PROFILE ENDING**
 product code: ZA100
 material: aluminium
 sales unit: piece

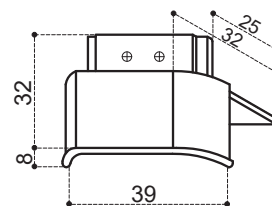

CEILING ACCESSORIES

name: **STRAIGHT CONNECTOR TO PSN-9145**
product code: **LP9145**
material: **aluminium**
sales unit: **piece**

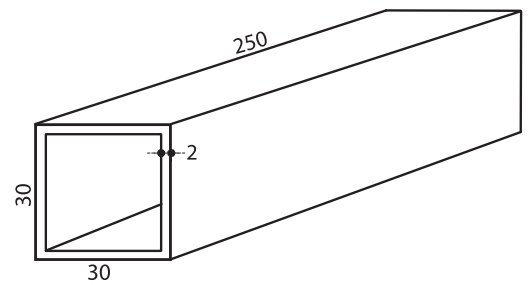

name: **CORNER CONNECTOR TO PSN-9145**
product code: **LPC50**
material: **aluminium**
sales unit: **piece**

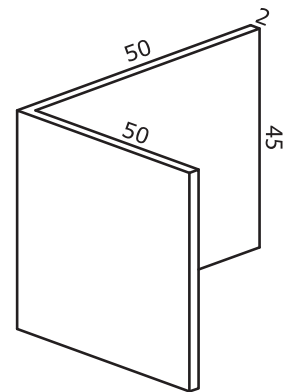

name: **CORNER CONNECTOR TO PSN-9145**
product code: **LC9145**
material: **steel**
sales unit: **piece**

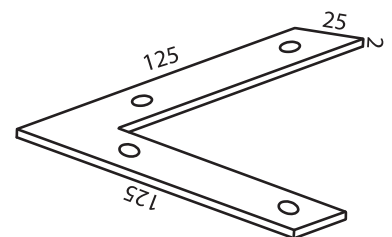

name: **CORNER CONNECTOR TO PSN-9145**
product code: **LC9145WP**
material: **stainless steel**
sales unit: **piece**

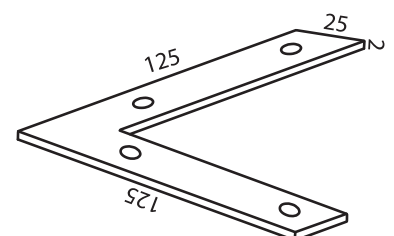

KR 30/KR 60 INSPECTION HATCH

The hatch allows you to cover the inspection hole in an aesthetic manner with any membrane from the Mat, Satine, Laque or Metallic range.

Made in the Wall2Wall system, the hatch door blends in with the ceiling and remains practically invisible.

Additionally, our product is very easy to open and close thanks to the use of Push Lock latches.

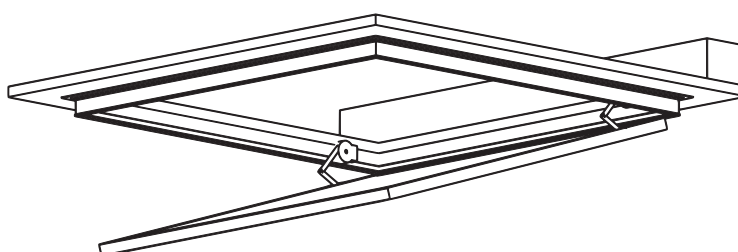
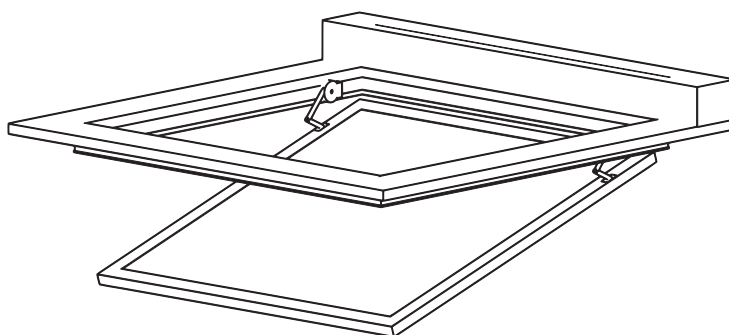
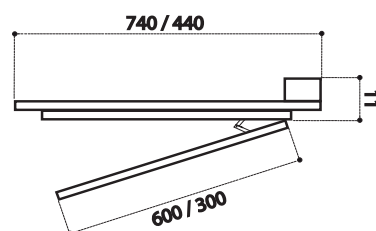
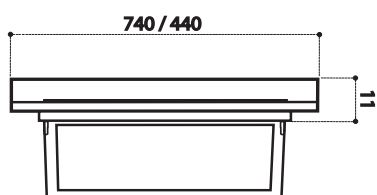
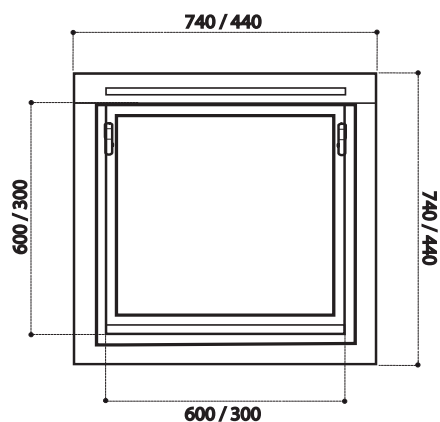

	KR 60	KR 30
name:	KR 60	KR 30
product code:	KR60	KR30
material:	12 mm plywood, components	12 mm plywood, components
dimensions:	60 x 60 cm	30 x 30 cm
weight:	7,0 kg	3,5 kg
compatibility:	alu harpoon + W2W	alu harpoon + W2W

On individual order
it is possible to produce
any requested size.

CEILING PERFORATION SUPPORT SHEET

name	C / model	a / internal diameter [mm]	b / external diameter [mm]	material
grommet	PC	5	10, 15, 20, 25	hard PVC 2mm hard PVC 3mm PC 2mm PC 3mm
	PC	10	15, 20, 25, 30	
	PC	15	20, 25, 30, 35	
	PC	20	30, 40	
	PC	20 - 40	+20mm	
pastille	PC	45 - 155	+20mm	
ring	PK	40 - 155	+50mm	foam PVC 10mm

name	model / product code	length [mm]	width [mm]	thickness [mm]	material
metal sheet	CMS1	1000	35	0.8	galvanized steel

The system codes are created according to a C a/b algorithm, where:

C = model

a = internal diameter

b = external diameter

For example, a ring with an internal diameter of 60 mm: PK 60/110

We make non-standard strengthening elements for ceiling sheet perforation as well as load-bearing structures for light fittings, ventilation grilles, speakers, fire sprinklers, etc. For this purpose, it is necessary to send a drawing of the required element with dimensions for its production and to specify the material it should be made of.

Our commercial assistants will contact you to present the offer.

CEILING ACCESSORIES

PC Ø5 grommet
thickness: 2; 3mm

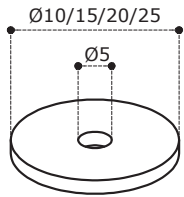

PC Ø 10 grommet
thickness: 2; 3mm

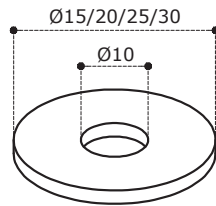

PC Ø 15 grommet
thickness: 2; 3mm

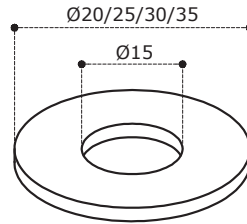

PC Ø 20 grommet
thickness: 2; 3mm

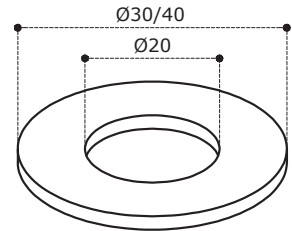

PC Ø 30-40 grommet
thickness: 2; 3mm

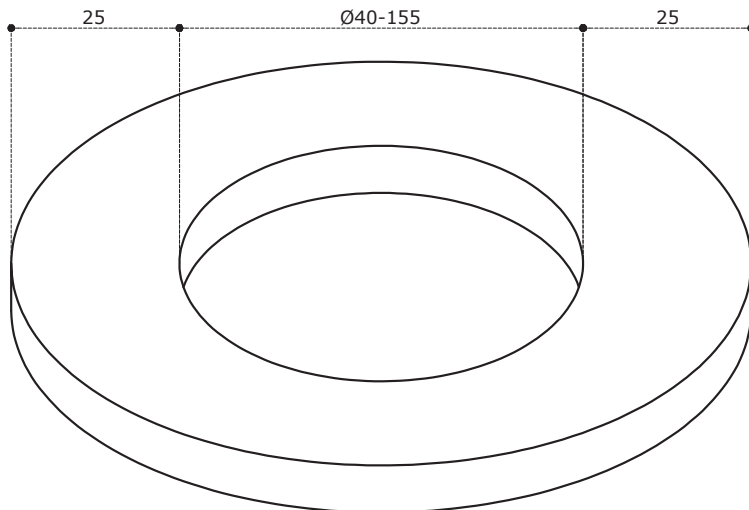
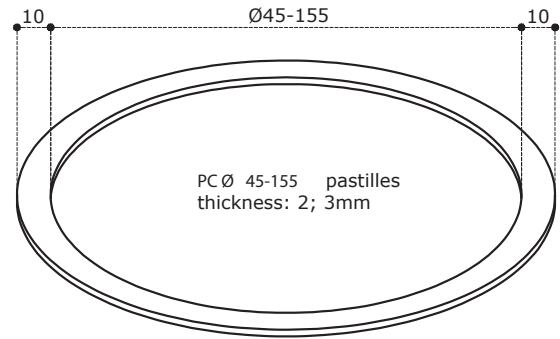
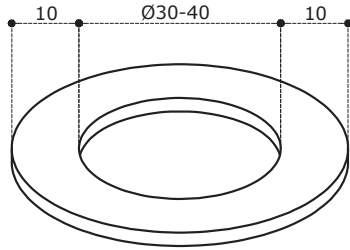

PK Ø 40-155 rings
thickness: 10mm

EXEMPLARY SUPPORTING PASTILLES USE

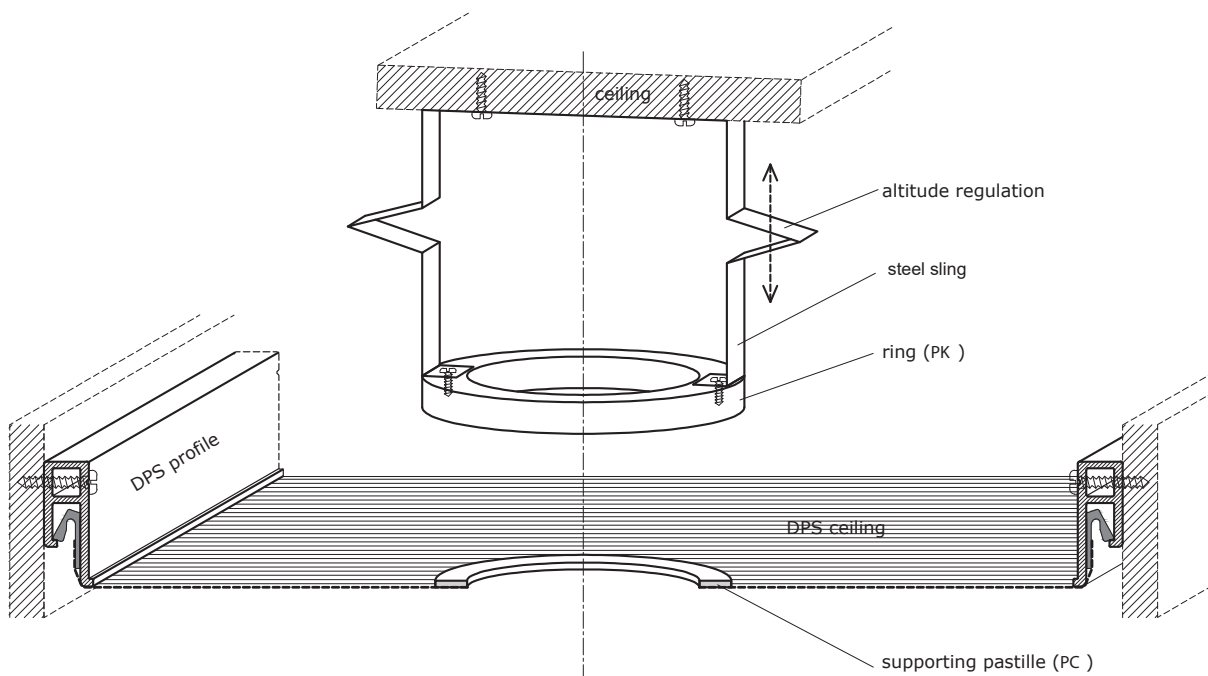
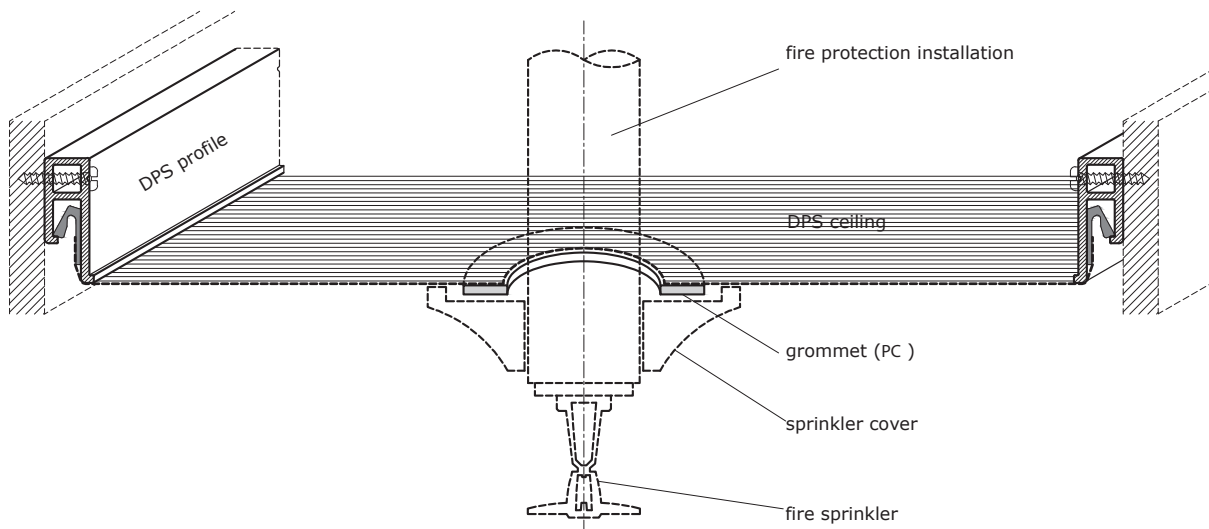

All contents and technical solutions included in this manual are the technical and intellectual property of Grupa DPS sp. z o.o.

Any unauthorized reproduction, translation and distribution, in whole or in part, will be prosecuted and punished in accordance with applicable copyright protection and intellectual property law.

Date of issue: 09/2024

Current version of the catalog available in digital version:
dpsceilings.com/marketing/DPS_technical_catalogue.pdf

STAY UP TO DATE!

DOWNLOAD THE CURRENT



PDF CATALOGUE

technical solutions



instructions
profiles
accessories

GRUPA DPS sp. z o.o.
ul. Krakowska 85A
40-391 Katowice, Poland

+48 32 204 96 80
+48 32 209 98 23

info@grupadps.com

www.dpsceilings.com